

PL = 1/2
aaw



HP 75000 SERIES C

HP E1451/E1452 20MHz Pattern I/O Modules

Hardware Manual



Copyright © Hewlett-Packard Company, 1991-1994
All rights reserved.



E1451-90002
E0294

CERTIFICATION

Hewlett-Packard Company certifies that this product met its published specifications at the time of shipment from the factory. Hewlett-Packard further certifies that its calibration measurements are traceable to the United States National Institute of Standards and Technology (formerly National Bureau of Standards), to the extent allowed by that organization's calibration facility, and to the calibration facilities of other International Standards Organization members.

WARRANTY

This Hewlett-Packard product is warranted against defects in materials and workmanship for a period of three years from date of shipment. Duration and conditions of warranty for this product may be superseded when the product is integrated into (becomes a part of) other HP products. During the warranty period, Hewlett-Packard Company will, at its option, either repair or replace products which prove to be defective.

For warranty service or repair, this product must be returned to a service facility designated by Hewlett-Packard (HP). Buyer shall prepay shipping charges to HP and HP shall pay shipping charges to return the product to Buyer. However, Buyer shall pay all shipping charges, duties, and taxes for products returned to HP from another country.

HP warrants that its software and firmware designated by HP for use with a product will execute its programming instructions when properly installed on that product. HP does not warrant that the operation of the product, or software, or firmware will be uninterrupted or error free.

LIMITATION OF WARRANTY

The foregoing warranty shall not apply to defects resulting from improper or inadequate maintenance by Buyer, Buyer-supplied products or interfacing, unauthorized modification or misuse, operation outside of the environmental specifications for the product, or improper site preparation or maintenance.

The design and implementation of any circuit on this product is the sole responsibility of the Buyer. HP does not warrant the Buyer's circuitry or malfunctions of HP products that result from the Buyer's circuitry. In addition, HP does not warrant any damage that occurs as a result of the Buyer's circuit or any defects that result from Buyer-supplied products.

NO OTHER WARRANTY IS EXPRESSED OR IMPLIED. HP SPECIFICALLY DISCLAIMS THE IMPLIED WARRANTIES OF MERCHANTABILITY AND FITNESS FOR A PARTICULAR PURPOSE.

EXCLUSIVE REMEDIES

THE REMEDIES PROVIDED HEREIN ARE BUYER'S SOLE AND EXCLUSIVE REMEDIES. HP SHALL NOT BE LIABLE FOR ANY DIRECT, INDIRECT, SPECIAL, INCIDENTAL, OR CONSEQUENTIAL DAMAGES, WHETHER BASED ON CONTRACT, TORT, OR ANY OTHER LEGAL THEORY.

NOTICE

The information contained in this document is subject to change without notice. HEWLETT-PACKARD (HP) MAKES NO WARRANTY OF ANY KIND WITH REGARD TO THIS MATERIAL, INCLUDING, BUT NOT LIMITED TO, THE IMPLIED WARRANTIES OF MERCHANTABILITY AND FITNESS FOR A PARTICULAR PURPOSE. HP shall not be liable for errors contained herein or for incidental or consequential damages in connection with the furnishing, performance or use of this material. This document contains proprietary information which is protected by copyright. All rights are reserved. No part of this document may be photocopied, reproduced, or translated to another language without the prior written consent of Hewlett-Packard Company. HP assumes no responsibility for the use or reliability of its software on equipment that is not furnished by HP.

Restricted Rights Legend

Use, duplication, or disclosure by the Government is subject to restrictions as set forth in subdivision (b)(3)(ii) of the Rights in Technical Data and Computer Software clause at 52.227-7013. Hewlett-Packard Company; 3000 Hanover Street, Palo Alto, California 94304

Declaration of Conformity

According to ISO/IEC Guide 22 and EN 45014

The Hewlett-Packard Company declares that the HP 75000 Model D20 E145xA Series modules and pods conforms to the following Product Specifications.

Safety:	IEC 1010-1 (1990) Incl. Amend 1 (1992)/EN61010 (1993) CSA C22.2 #1010.1 (1992) UL 1244
EMC:	CISPR 11:1990/EN 55011 (1991): Group 1 Class A IEC 801-2:1991/EN 50082-1 (1992): 4kVCD, 8kVAD IEC 801-3:1984/EN 50082-1 (1992): 3 V/m IEC 801-4:1988/EN 50082-1 (1992): 1kV Power Line

Supplementary Information: The product herewith complies with the requirements of the low voltage Directive 73/23/EEC and the EMC Directive 89/336/EEC.

Tested in a typical configuration in an HP C-size VXI mainframe.

Q.A. Manager
February 1994

Hewlett-Packard Company
P.O. Box 301
815 14th Street S.W.
Loveland, Colorado 80539 U.S.A.

Printing History

The Printing History shown below lists all Editions and Updates of this manual and the printing date(s). The first printing of the manual is Edition 1. The Edition number increments by 1 whenever the manual is revised. Updates, which are issued between Editions, contain replacement pages to correct the current Edition of the manual. Updates are numbered sequentially starting with Update 1. When a new Edition is created, it contains all the Update information for the previous Edition. Each new Edition or Update also includes a revised copy of this printing history page. Many product updates or revisions do not require manual changes and, conversely, manual corrections may be done without accompanying product changes. Therefore, do not expect a one-to-one correspondence between product updates and manual updates.

Edition 1 (Part Number E1451-90001) June 1991

Edition 2 (Part Number E1451-90002) February 1994

Safety Symbols



Instruction manual symbol affixed to product. Indicates that the user must refer to the manual for specific Warning or Caution information to avoid personal injury or damage to the product.



Indicates the field wiring terminal that must be connected to earth ground before operating the equipment—protects against electrical shock in case of fault.



OR



Frame or chassis ground terminal—typically connects to the equipment's metal frame.



Alternating current (AC).



Direct current (DC).



Indicates hazardous voltages.

WARNING

Calls attention to a procedure, practice, or condition that could cause bodily injury or death.

CAUTION

Calls attention to a procedure, practice, or condition that could possibly cause damage to equipment or permanent loss of data.

WARNINGS

The following general safety precautions must be observed during all phases of operation, service, and repair of this product. Failure to comply with these precautions or with specific warnings elsewhere in this manual violates safety standards of design, manufacture, and intended use of the product. Hewlett-Packard Company assumes no liability for the customer's failure to comply with these requirements.

Ground the equipment: For Safety Class 1 equipment (equipment having a protective earth terminal), an uninterruptible safety earth ground must be provided from the mains power source to the product input wiring terminals or supplied power cable.

DO NOT operate the product in an explosive atmosphere or in the presence of flammable gases or fumes.

For continued protection against fire, replace the line fuse(s) only with fuse(s) of the same voltage and current rating and type. DO NOT use repaired fuses or short-circuited fuse holders.

Keep away from live circuits: Operating personnel must not remove equipment covers or shields. Procedures involving the removal of covers or shields are for use by service-trained personnel only. Under certain conditions, dangerous voltages may exist even with the equipment switched off. To avoid dangerous electrical shock, DO NOT perform procedures involving cover or shield removal unless you are qualified to do so.

DO NOT operate damaged equipment: Whenever it is possible that the safety protection features built into this product have been impaired, either through physical damage, excessive moisture, or any other reason, REMOVE POWER and do not use the product until safe operation can be verified by service-trained personnel. If necessary, return the product to a Hewlett-Packard Sales and Service Office for service and repair to ensure that safety features are maintained.

DO NOT service or adjust alone: Do not attempt internal service or adjustment unless another person, capable of rendering first aid and resuscitation, is present.

DO NOT substitute parts or modify equipment: Because of the danger of introducing additional hazards, do not install substitute parts or perform any unauthorized modification to the product. Return the product to a Hewlett-Packard Sales and Service Office for service and repair to ensure that safety features are maintained.

Manual Contents

Hardware Descriptions

HP E1451/E1452 Pattern I/O Hardware Description	1-1
HP E1454 Pattern I/O Pod Description	1-3
Using the HP E1451/E1452 as a Stand-Alone Instrument	1-4

Configuration and Wiring

Using this Chapter	2-1
Configuration Information	2-2
Logical Address Guidelines	2-2
Logical Address Switch	2-2
Wiring Information	2-4
Recommended Fixturing Techniques	2-7

Register Maps

Using This Chapter	3-1
Register Addresses	3-1
The Base Address	3-3
Register Offset	3-3
Register Definitions	3-5
ID Register (Read)	3-5
Device Type (Read)	3-5
Status/Control Register (Read)	3-5
Status/Control Register (Write)	3-6
Calibration ROM Register (Read/Write)	3-6
I/O Port Registers	3-6
Sequence Memory (Read/Write)	3-6
Branch Destination (Read/Write)	3-7
Port Data Bus (Read/Write)	3-8
Configuration Register (Read/Write)	3-8
I/O Control (Read/Write)	3-10
Status/Clock Source Register (Write)	3-12
Status/Clock Source Register (Read)	3-14
Mask/Calibration Value Register (Read/Write)	3-14

Specifications

Sequencer Specifications	A-1
Specifications For Ports Configured As Outputs	A-1
Specifications For Ports Configured As Inputs	A-2
External Clock Input Specifications	A-3
Miscellaneous Specifications	A-3

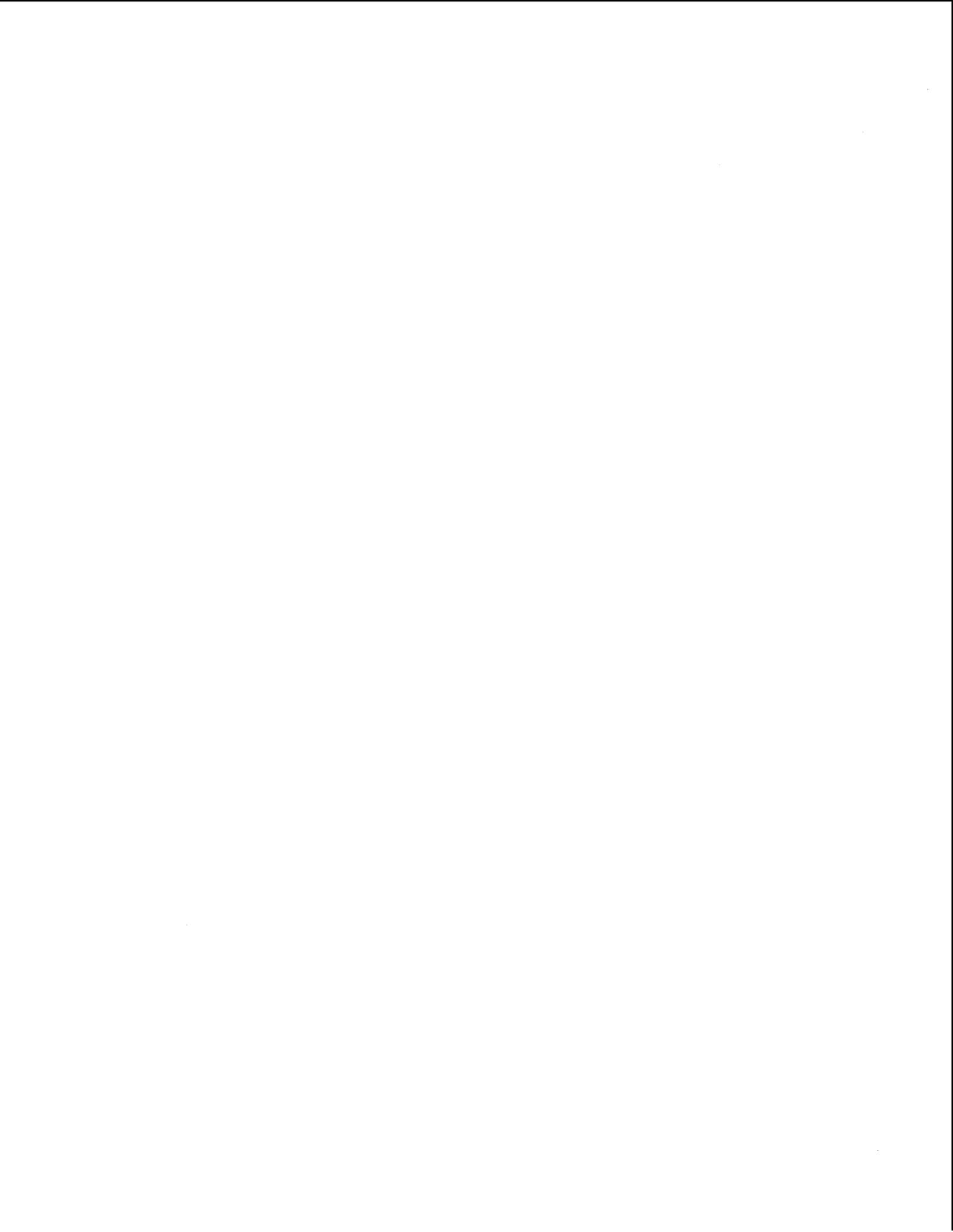

Chapter Contents

Hardware Descriptions

HP E1451/E1452 Pattern I/O Hardware Description 1-1
HP E1454 Pattern I/O Pod Description 1-3
Using the HP E1451/E1452 as a Stand-Alone Instrument 1-4

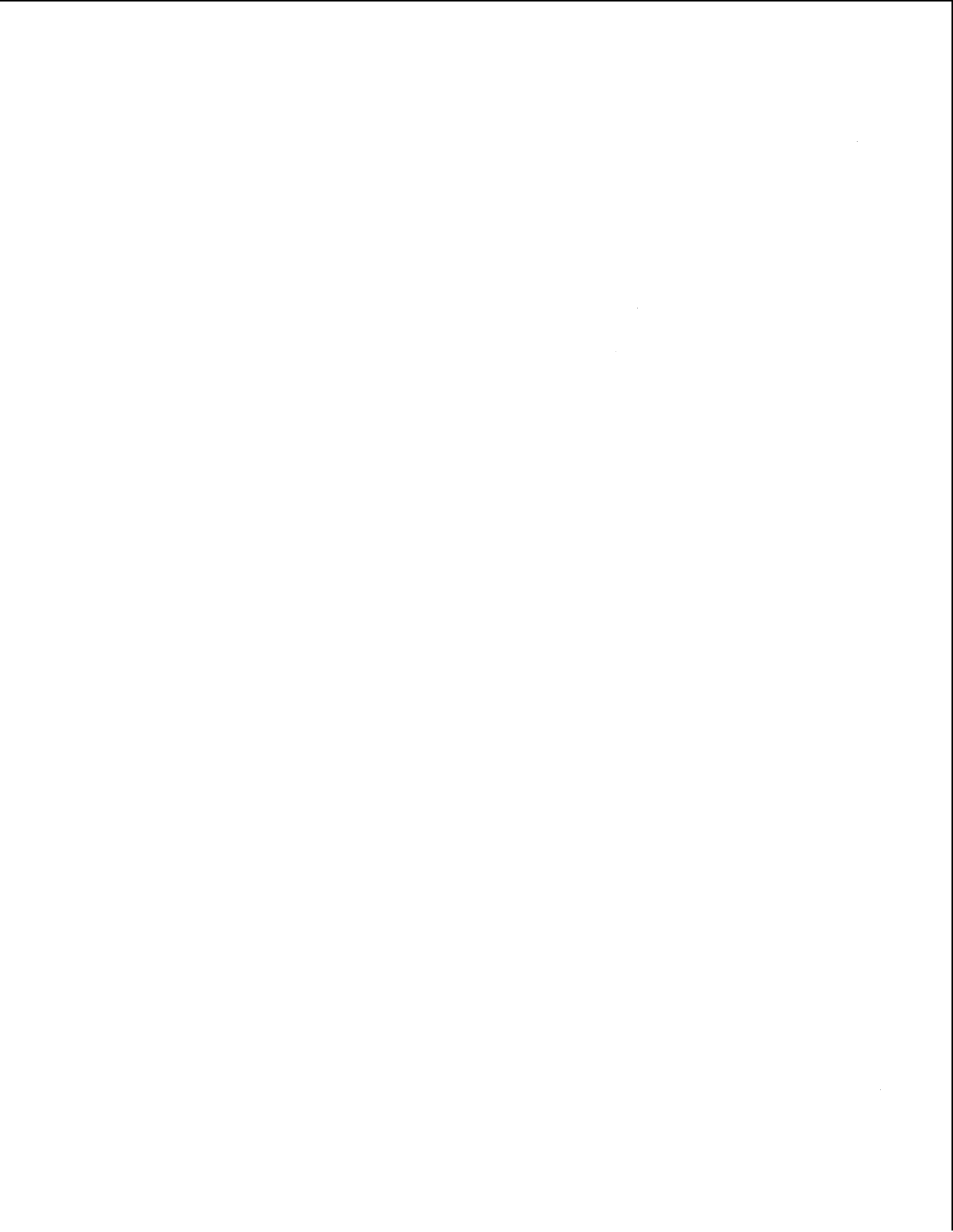

Chapter 1

Hardware Descriptions

HP E1451/E1452 Pattern I/O Hardware Description

The HP E1451 Pattern I/O Module and HP E1452 Terminating Pattern I/O Module (Figure 1-1) are single slot, C-size VXIbus register-based modules. They are used to send or receive pattern data to/from the DUT (Device Under Test). Each I/O module contains four identical 8-pin ports (32 I/O pins). Each port can be independently programmed to either output (stimulus), record (response), or real-time compare (response). A module block diagram is shown on the following page.

Each port has a 64k-byte deep sequence memory for holding patterns and control bits. Multiple test sequences may co-reside in this memory. To eliminate skew errors caused by timing variation between ports, each port has its own programmable delay device. This device is programmed based on constants stored in the module's calibration memory.

The HP E1451 and HP E1452 are identical except that the HP E1451 passes along the Local Bus pattern clocks to the next module whereas the HP E1452 terminates the pattern clock lines. The HP E1452 Terminating Pattern I/O Module must be the last module of the Pattern I/O module set so the Local Bus is properly terminated when the HP E1450 Timing Module is used. If external timing is used in lieu of the timing module, then only the HP E1451 Pattern I/O module is required.

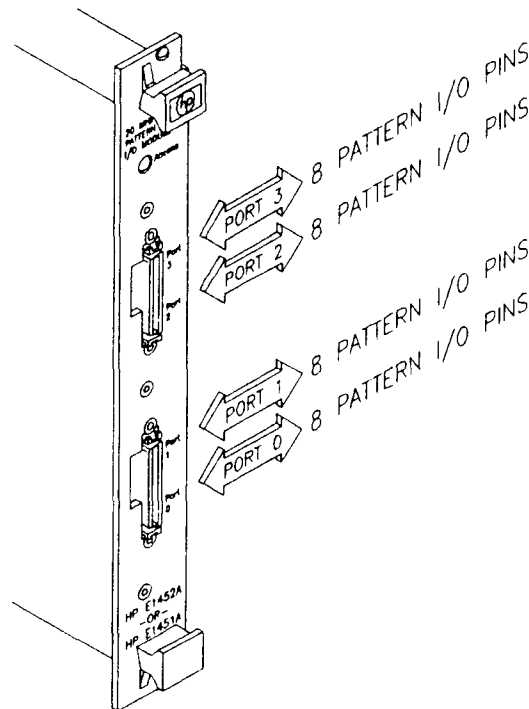

Figure 1-1. HP E1451/E1452 Pattern I/O Module

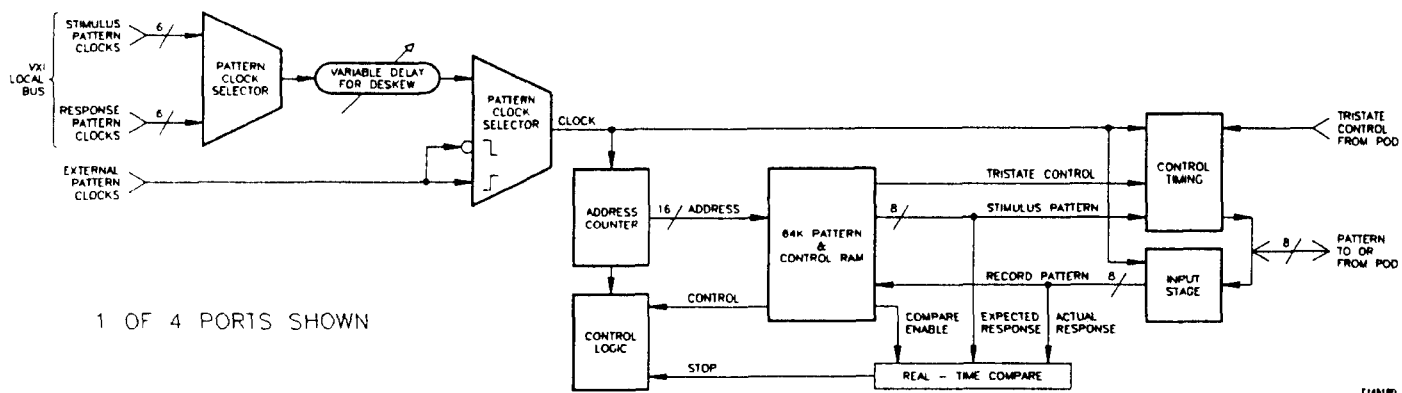

Figure 1-2. Pattern I/O Block Diagram

HP E1454 Pattern I/O Pod Description

The optional HP E1454 Pattern I/O Pod (Figure 1-3) extends measurement accuracy to a DUT located up to two meters from the front panel of the Model D20. The pods buffer the input and output signals for two of the four HP E1451/E1452 I/O ports. This improves the Model D20's ability to drive DUT inputs and minimizes loading on DUT outputs. Response pattern clocks are delayed relative to the stimulus pattern clocks by the Timing Module so that timing is correct at the DUT. And pin-to-pin skew on the pattern I/O lines is compensated, based on constants stored in the pod's calibration memory. The pattern I/O pods also provide inputs for tri-state control and external clock. The HP E1454 is supplied with a 2.1-meter cable. Two HP E1454 pods are required for each HP E1451/E1452 in the Model D20.

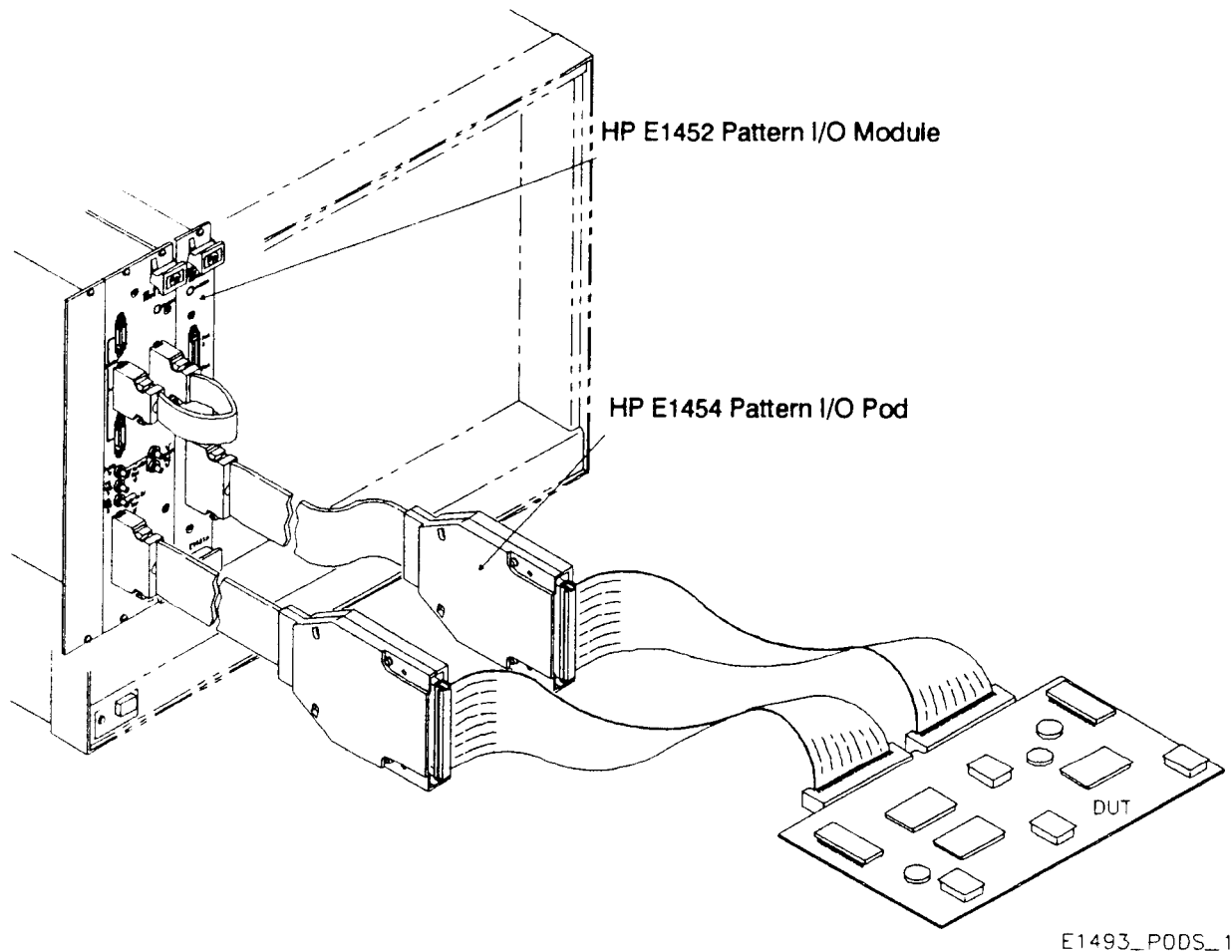

Figure 1-3. Pattern I/O Module/Pod

Using the HP E1451/E1452 as a Stand-Alone Instrument

You can use the pattern module as a stand-alone digital I/O instrument without the need for an HP E1450 Timing Module. In this configuration, the pattern module must have a logical address that is a direct multiple of 8 (i.e., 8, 16, 24, 32, . . . 240). You must also use an external clock source since the Timing Module is not present (refer to "Using External Clocks" in chapter 3 of the Model D20 Task and Command Reference). When used as a stand-alone instrument, the pattern module is capable of executing only those commands shown in Table 1-1. Refer to the Command Reference, chapter 4 of the Model D20 Task and Command Reference Manual for details about these commands.

↳ PN E1493 - 90030
includes this manual

Table 1-1. Stand-Alone Pattern Module Command Set

DIGital Subsystem

:GROup

```
:CATalog?
:DEFine <name>,<port_list>
:DEFine? <group_name>
:DELetc:ALL
:DELetc[:NAME] <group_name>
:MODE RESPonse|STIMulus
:MODE?
[:SElect] <group_name>|NONE
[:SElect]?
```

:RESPonse

```
:COMParE
:ENABle
:SEQuence
[:FULL] <boolean_block>
[:FULL]?
:PARTial <start_vector>,1|0|ON|OFF{,1|0|ON|OFF}
:PARTial? <start_vector>,<count>
:REPeat <start_vector>,<count>,1|0|ON|OFF
[:STATE] 1|0|ON|OFF
[:STATE]?
:ERRor?
:MASK[:VALue] <pattern_value>
:MASK[:VALue]?
:PATTERn
:SEQuence
[:FULL] <pattern_block>
[:FULL]?
:PARTial <start_vector>,<pattern_value>
{,<pattern_value>}
:PARTial? <start_vector>,<count>
:REPeat <start_vector>,<count>,<pattern_value>
[:VALue]?
:CLOCK
:EXTernal:SLOPe POSitive|NEGative
:EXTernal:SLOPe?
:SOURce HOLD|EXTernal
:SOURce?
```

:SEQuence

```
:CATalog?
:DEFine <name>,<#_vectors>
:DEFine? <seq_name>
:DELetc:ALL
:DELetc[:NAME] <seq_name>
:POSition?
[:SElect] <seq_name>|NONE
[:SElect]?
:WINDow
:BOUNDary <start_vector>,<stop_vector>
:BOUNDary?
[:STATE] 1|0|ON|OFF
[:STATE]?
```

:STIMulus

```
:ENABle
:SEQuence
[:FULL] <boolean_block>
[:FULL]?
:PARTial <start_vector>,1|0|ON|OFF{,1|0|ON|OFF}
:PARTial? <start_vector>,<count>
:REPeat <start_vector>,<count>,1|0|ON|OFF
```

```
[:VALue] 1|0|ON|OFF
[:VALue]?
:PATTERn
:SEQuence
[:FULL] <pattern_block>
[:FULL]?
:PARTial <start_vector>,<pattern_value>
{,<pattern_value>}
:PARTial? <start_vector>,<count>
:REPeat <start_vector>,<count>,<pattern_valu
[:VALue] <pattern_value>
[:VALue]?
:CLOCK
:EXTernal:SLOPe POSitive|NEGative
:EXTernal:SLOPe?
:SOURce HOLD|EXTernal
:SOURce?
```

System Operation Commands

```
RUN
STOP
```

System Status, Management, and Test Commands

STATus

```
:OPERation
[:EVENT]?
:CONDition?
:ENABle <pattern_value>
:ENABle?
:NTRansition <pattern_value>
:NTRansition?
:PTRansition <pattern_value>
:PTRansition?
:PRESet
:QUEStionable
[:EVENT]?
:CONDition?
:ENABle <pattern_value>
:ENABle?
:NTRansition <pattern_value>
:NTRansition?
:PTRansition <pattern_value>
:PTRansition?
```

SYSTem

```
:ERRor?
:PRESet
:VERsion?
```

TEST

```
[:ALL]?
:MODule? <module_#>
```

Query Data Format Commands

FORMat

```
[:DATA] ASCii|HEXadecimal|OCTal|BINary
[:DATA]?
```

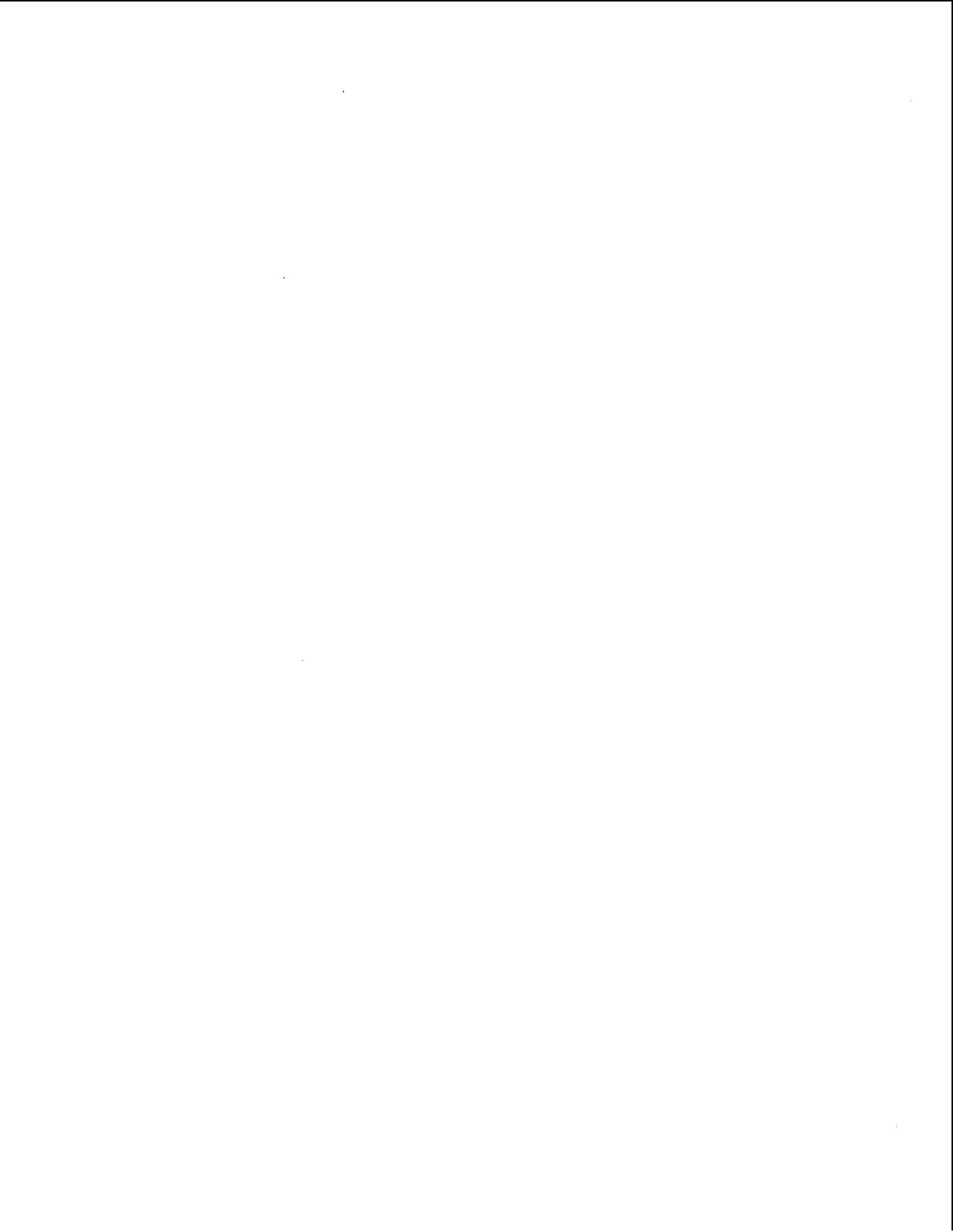

Chapter Contents

Configuration and Wiring

Using this Chapter	2-1
Configuration Information	2-2
Logical Address Guidelines	2-2
Logical Address Switch	2-2
Wiring Information	2-4
Recommended Fixturing Techniques	2-7



Chapter 2

Configuration and Wiring

Using this Chapter

This chapter contains configuration and wiring information for the HP E1451/E1452 Pattern I/O Modules, the optional HP E1454 Pattern I/O Pods, and the optional module to DUT interface cables. For complete details on installing this equipment in a C-Size mainframe, refer to the "HP 75000 Model D20 Hardware Installation Guide" and the "C-Size VXIbus Systems Installation and Getting Started Guide".

WARNING

SHOCK HAZARD. Only service-trained personnel who are aware of the hazards involved should install, remove, or configure the system. Before you perform any procedures in this guide, disconnect AC power and field wiring from the mainframe.

Caution

STATIC ELECTRICITY. Static electricity is a major cause of component failure. To prevent damage to the electrical components in the mainframe and plug-in modules, observe anti-static techniques whenever handling a module.

Configuration Information

This section shows you how to set the module's logical address switch.

Logical Address Guidelines

- The HP E1450 Timing Module must have a Logical Address that is an Instrument Identifier. An Instrument Identifier is a Logical Address that is an exact multiple of 8 (i.e., 8, 16, 24, 32, . . . 240).
- HP E1451 Pattern I/O and E1452 Terminating I/O modules must have successive Logical Addresses beginning with the address of the Instrument Identifier. The HP E1452 Terminating I/O Module must have the highest Logical Address (last in the list).

NOTE

When using an HP E1451 or E1452 as a stand-alone instrument (no other modules involved), it must have a Logical Address that is an Instrument Identifier (an exact multiple of 8).

Logical Address Switch

Figure 2-1 shows a Logical Address Switch. Notice that the switch is made up of 8 switches each having a decimal value. To determine the Logical Address, add the decimal values of all set switches. For example, if you set switches 7 and 3 to "1" (see Figure 2-1), the logical address is $128 + 8 = 136$. The HP-IB Secondary Address is determined by dividing the Instrument Identifier by 8. For example, if the Instrument Identifier logical address is 136, the Secondary Address is $136 / 8 = 17$. Figure 2-2 shows how to set the Logical Address switch.

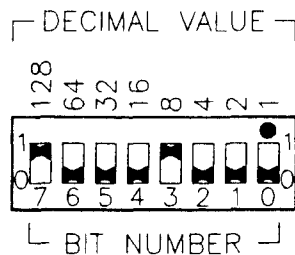
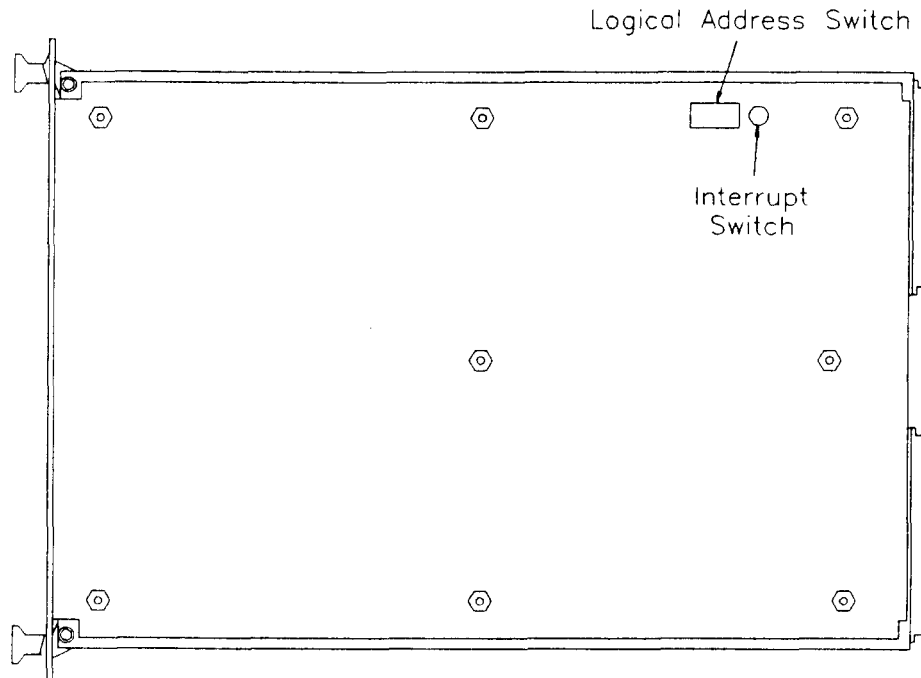

Figure 2-1. Logical Address Switch



EXAMPLES:

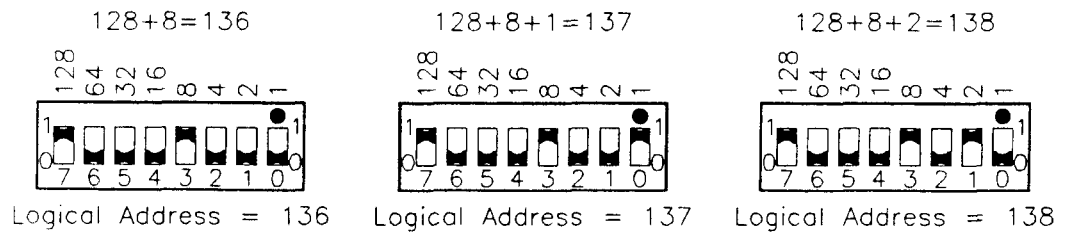

Figure 2-2. Setting a Logical Address Switch

NOTE

Plug-in modules also contain Interrupt Switches. We recommend that you leave these switches set to 1 (factory setting). This causes the modules to use interrupt line 1 which is the default line for most interrupt handlers (command module, embedded controller, etc.). Refer to the "C-Size VXibus Systems Installation and Getting Started Guide" if you need more information on Interrupt Switches.

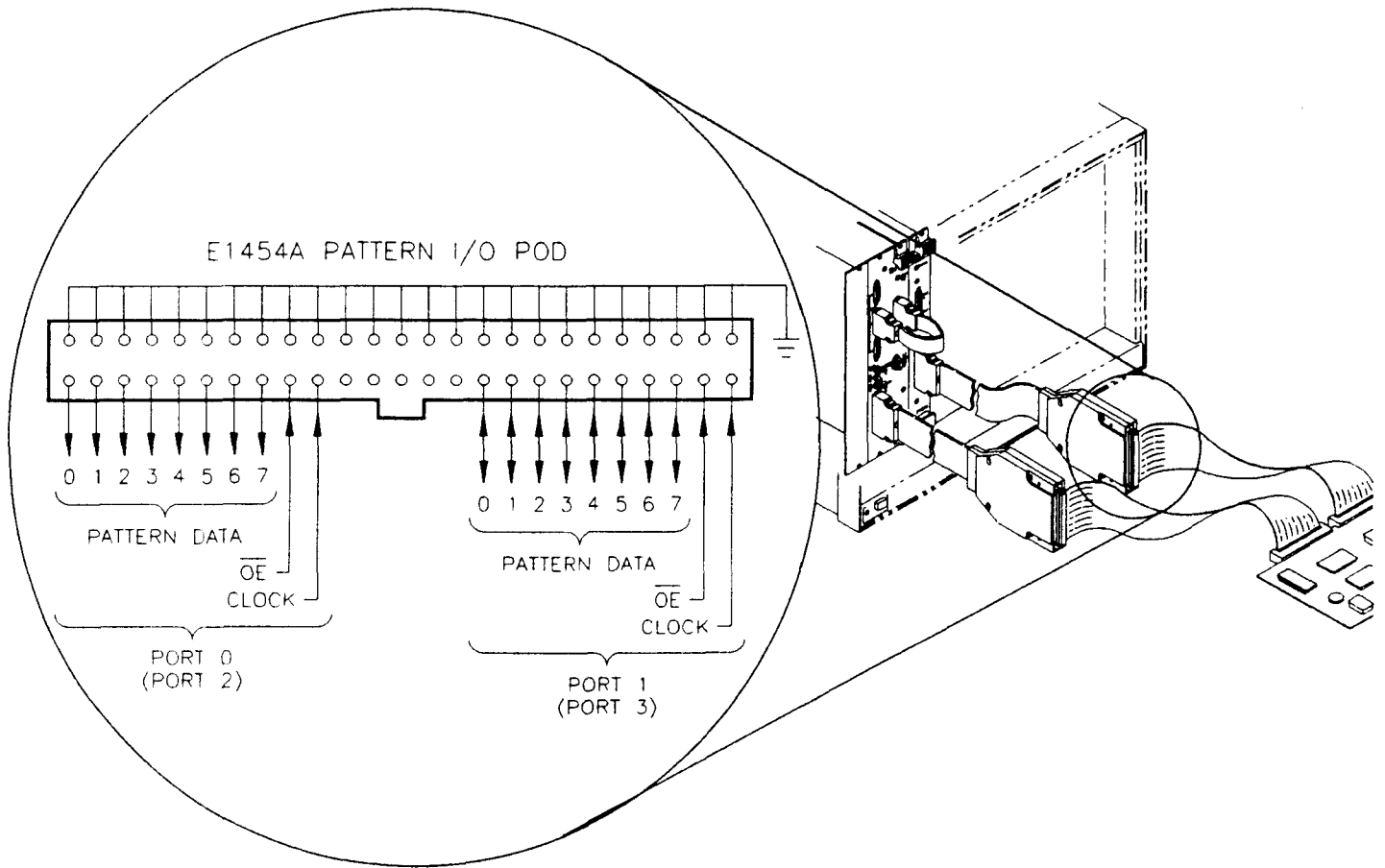
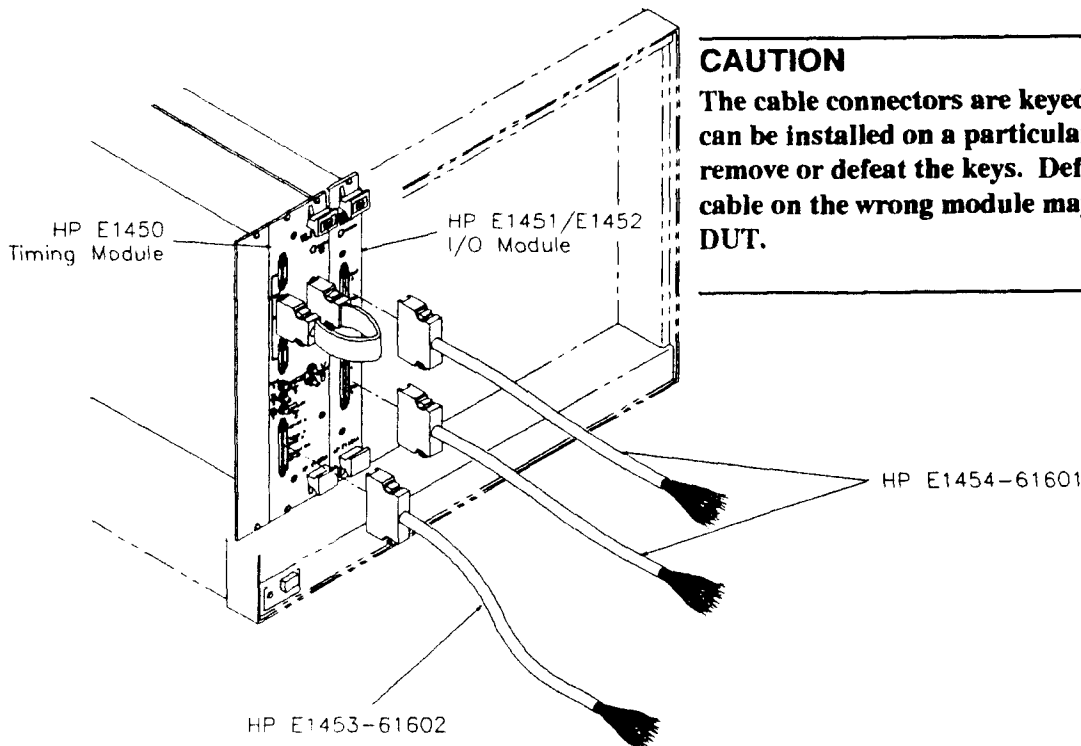

Figure 2-4. Pattern I/O Pod Connector

CAUTION

The pod connectors are keyed so that only the correct pod can be installed on a particular plug-in module. Do not remove or defeat the keys. Defeating a key and installing a pod on the wrong module will damage the module and the pod.



CAUTION

The cable connectors are keyed so that only the correct cable can be installed on a particular plug-in module. Do not remove or defeat the keys. Defeating a key and installing a cable on the wrong module may damage the module and the DUT.

Figure 2-5. Module to DUT Interface Cables

Table 2-1. Pattern I/O (HP E1454-61601) Wiring

Pin	Color	Signal	Pin	Color	Signal
1	NC		2	NC	
3	RED/BLUE	D0 (Port 0 or 2)	4	NC	
5	WHITE/BROWN	D1 (Port 0 or 2)	6	NC	
7	RED/ORANGE	D2 (Port 0 or 2)	8	VIOLET/BLUE	GROUND
9	WHITE/ORANGE	D3 (Port 0 or 2)	10	NC	
11	RED/GREEN	D4 (Port 0 or 2)	12	NC	
13	WHITE/GREEN	D5 (Port 0 or 2)	14	NC	
15	WHITE/BLUE	D6 (Port 0 or 2)	16	NC	
17	RED/BROWN	D7 (Port 0 or 2)	18	BLUE/VIOLET	GROUND
19	NC		20	VIOLET/ORANGE	GROUND
21	WHITE/GRAY	EXT CLK ₂ Port 0 or	22	YELLOW/BROWN	OE (Port 0 or 2)
23	NC		24	ORANGE/VIOLET	GROUND
25	NC		26	NC	
27	NC		28	VIOLET/GREEN	GROUND
29	RED/GRAY	EXT CLK ₃ Port 1 or	30	YELLOW/GRAY	OE (Port 1 or 3)
31	NC		32	GREEN/VIOLET	GROUND
33	BLACK/ORANGE	D0 (Port 1 or 3)	34	VIOLET/BROWN	GROUND
35	BLACK/BROWN	D1 (Port 1 or 3)	36	NC	
37	YELLOW/BLUE	D2 (Port 1 or 3)	38	NC	
39	BLACK/GREEN	D3 (Port 1 or 3)	40	NC	
41	BLACK/BLUE	D4 (Port 1 or 3)	42	NC	
43	YELLOW/ORANGE	D5 (Port 1 or 3)	44	BROWN/VIOLET	GROUND
45	BLACK/GRAY	D6 (Port 1 or 3)	46	NC	
47	YELLOW/GREEN	D7 (Port 1 or 3)	48	NC	
49	NC		50	NC	

Notes: NC = No Connection. Colors listed as main body color/stripe color. For example, WHITE/BROWN is a white wire with a brown stripe.

Recommended Fixturing Techniques

- The pod mating connector (Dut side) is a 50-pin (2 x 25) male dual in-line connector with 0.025-inch (0.64mm) round or square pins on 0.100-inch (2.54mm) centers. This connector is not supplied with the product and is available from electronic supply houses.
- Do not connect the device under test (DUT) directly to the pod connector. Whenever possible, use intermediate wiring between the pod mating connector and the test fixture connector (such as the PC Board Edge Connector shown below). This minimizes the number of insertions/removals made to the pod connector which extends its lifetime.
- Keep all wiring to the DUT as short as possible.

CAUTION

Clearly label the wiring and connectors to identify timing connections and I/O connections. Equipment or DUT damage can occur if these connections are accidentally reversed.

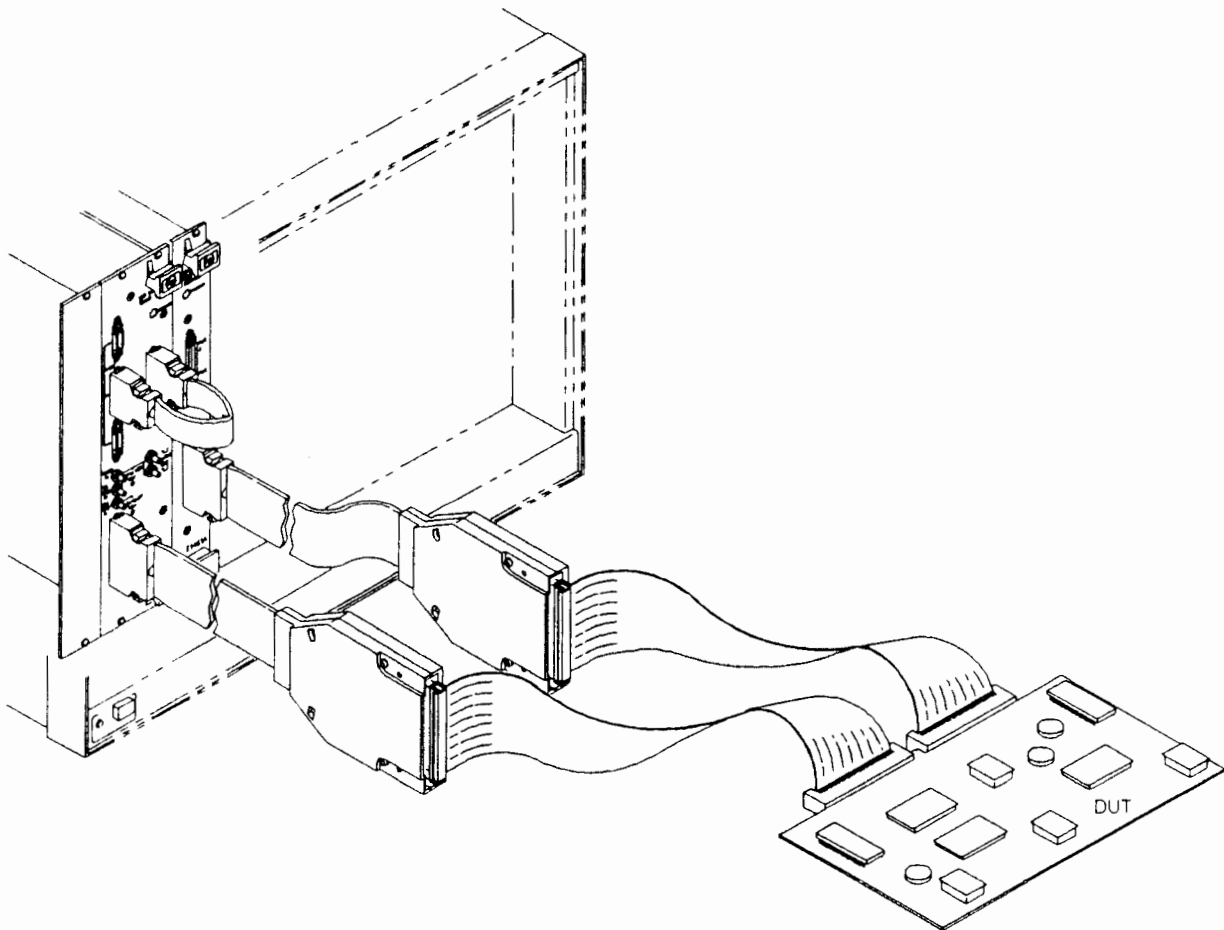

E1493_PODS_1

Figure 2-6. Recommended Fixturing Techniques

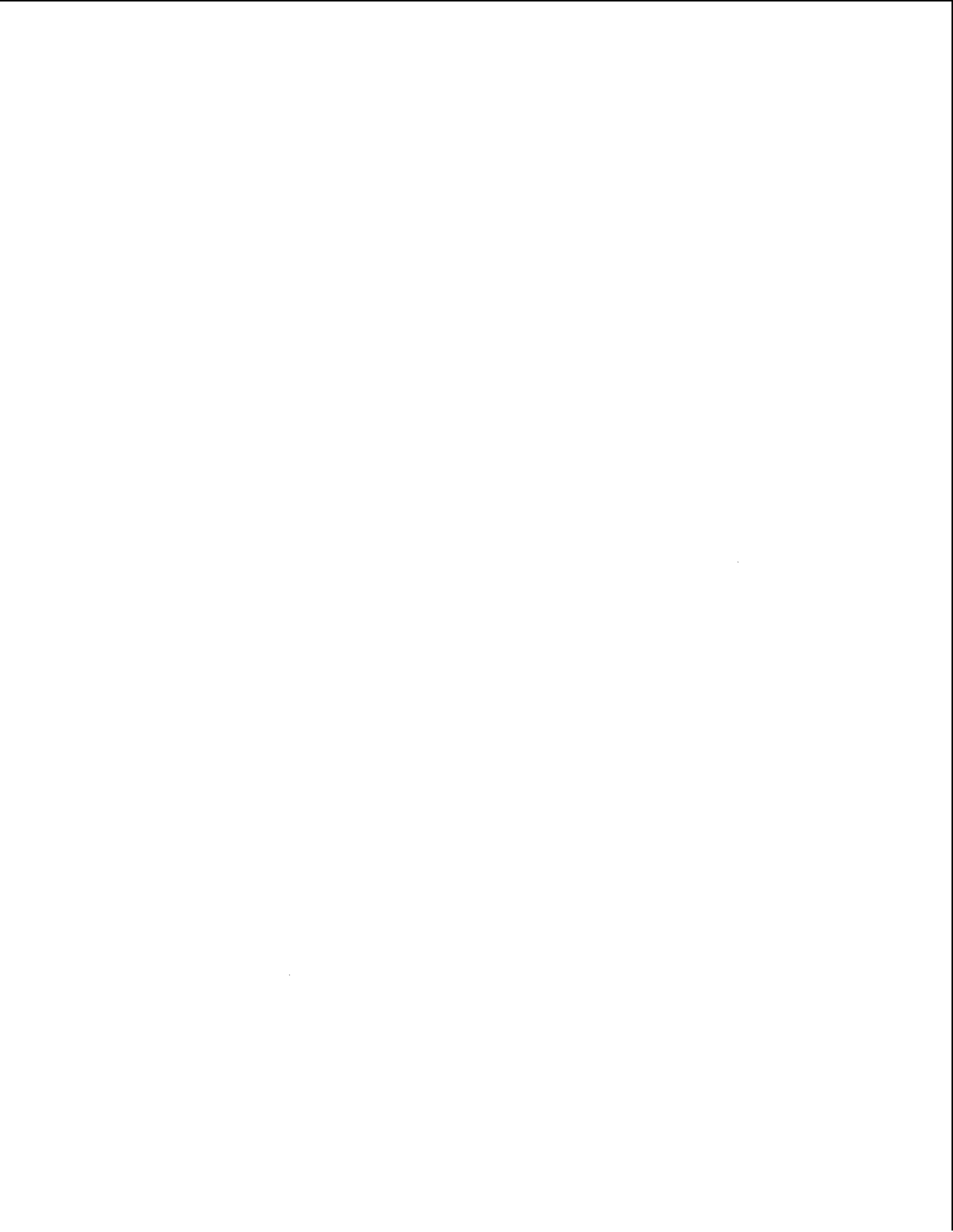

Chapter Contents

Register Maps

Using This Chapter	3-1
Register Addresses	3-1
The Base Address	3-3
A16 Address Space when not using the HP E1405 Command Module	3-3
A16 Address Space Using the Command Module	3-3
Register Offset	3-3
Register Definitions	3-5
ID Register (Read)	3-5
Device Type (Read)	3-5
Status/Control Register (Read)	3-5
Status/Control Register (Write)	3-6
Calibration ROM Register (Read/Write)	3-6
I/O Port Registers	3-6
Sequence Memory (Read/Write)	3-6
Branch Destination (Read/Write)	3-7
Port Data Bus (Read/Write)	3-8
Configuration Register (Read/Write)	3-8
I/O Control (Read/Write)	3-10
Status/Clock Source Register (Write)	3-12
Status/Clock Source Register (Read)	3-14
Mask/Calibration Value Register (Read/Write)	3-14

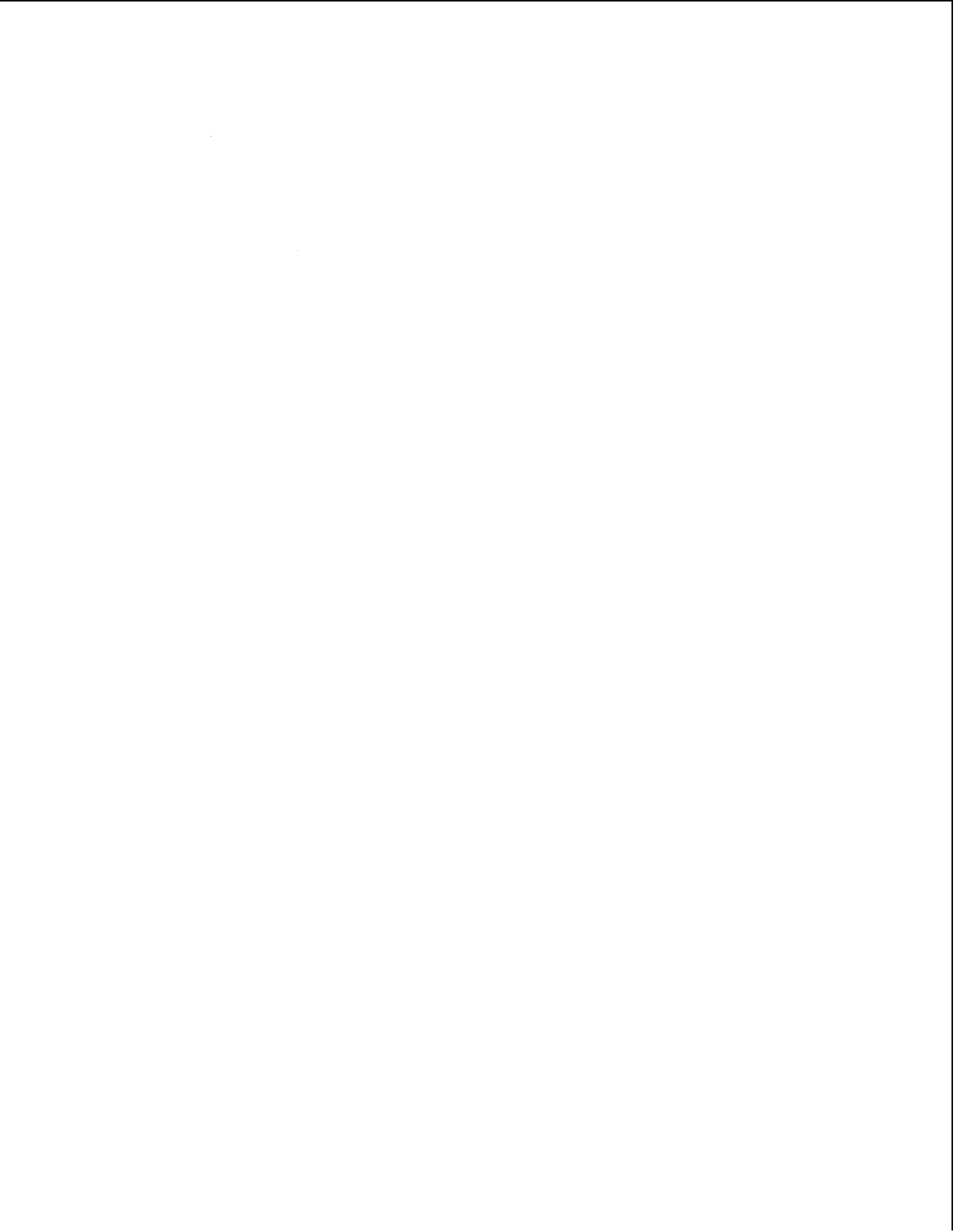

Chapter 3

Register Maps

Using This Chapter

The HP E1451/E1452 modules are a register-based devices. This chapter contains the register information for these modules.

CAUTION

The register maps in this chapter are included for reference information only. WE DO NOT RECOMMEND THAT YOU ATTEMPT TO PROGRAM THE MODEL D20 AT THE REGISTER LEVEL. Register-based programming of this product is difficult; requires in-depth knowledge of the internal workings of the product; can result in the erasure of calibration constants requiring the product to be serviced at an HP Service Center. REPAIRS MADE TO THE PRODUCT TO REPLACE CALIBRATION CONSTANTS ERASED BY REGISTER-BASED PROGRAMMING ARE NOT COVERED BY THE PRODUCT WARRANTY.

Register Addresses

The following table shows the HP E1451/E1452 register offset values within the A16 address space (note that a base address must be added to the register offset value to produce the register address).

Table 2-1. HP E1451/E1452 Registers within A16 Address Space.

Address (Hex)	Register Description
3E	Port 3 Mask/Calibration Value
3C	Port 3 Status/Clock Source
3A	Port 3 I/O Control
38	Port 3 Configuration
36	Port 3 Data Bus
34	Port 3 Branch Destination
32	Port 3 Sequence Memory Address
30	Port 2 Mask/Calibration Value
2E	Port 2 Status/Clock Source
2C	Port 2 I/O Control
2A	Port 2 Configuration
28	Port 2 Data Bus
26	Port 2 Branch Destination
24	Port 2 Sequence Memory Address
22	Port 1 Mask/Calibration Value
20	Port 1 Status/Clock Source
1E	Port 1 I/O Control
1C	Port 1 Configuration
1A	Port 1 Data Bus
18	Port 1 Branch Destination
16	Port 1 Sequence Memory Address
14	Port 0 Mask/Calibration Value
12	Port 0 Status/Clock Source
10	Port 0 I/O Control
0E	Port 0 Configuration
0C	Port 0 Data Bus
0A	Port 0 Branch Destination
08	Port 0 Sequence Memory Address
06	Calibration ROMs
04	Status/Control
02	Device Type
00	ID

The Base Address

To access a register, you must specify the register address in either hexadecimal or decimal. The register address consists of a base address plus a register offset. The base address depends on whether the A16 address space is accessed via the Series C HP E1405 Command Module or via some other controller.

A16 Address Space when not using the HP E1405 Command Module

When the Command Module or Mainframe is not part of your VXIbus system, the module's base address is computed by taking the controller specific offset and adding the following:

hexadecimal	decimal
$C000h + (LADDR * 64)h$	$49,152 + (LADDR * 64)$

where C000h (49,152) is the starting location of the register addresses, LADDR is the module's logical address, and 64 is the number of address bytes per register-based module. For example, the module's factory set logical address is 136. If this address is not changed, the module will have a base address consisting of the controller specific offset with the following added to it:

hexadecimal	decimal
$C000h + (136 * 64)h$ $C000h + 2200 = E200h$	$49,152 + (136 * 64)$ $49,152 + 8704 = 57,856$

A16 Address Space Using the Command Module

When the A16 address space is accessed via the Command Module, the module's base address is computed as:

hexadecimal	decimal
$1FC000h + (LADDR * 64)h$	$2,080,768 + (LADDR * 64)$

where 1FC000h (2,080,768) is the starting location of the register addresses, LADDR is the module's logical address, and 64 is the number of address bytes per register-based module. For example, the module's factory set logical address is 136. If this address is not changed, the module will have a base address of:

hexadecimal	decimal
$1FC000h + (136 * 64)h$ $1FC000h + 2200h = 1FE200h$	$2,080,768 + (136 * 64)$ $2,080,768 + 8704 = 2,089,472$

Register Offset

The register offset is the register's location in the block of 64 address bytes (see Table 2-1). For example, the module's Port 1 Mask/Calibration register has an offset of 22h. When writing a value to this register, this offset is added to the base address to form the register address:

Address Space	Hexadecimal Register Address	Decimal Register Address
Outside the command module	OFFSET + E200h + 22h = OFFSET + E222h	OFFSET + 57,856 + 34 = OFFSET + 57,890 + 34 = 52,258
Inside the command module	1FE200h + 22h = 1FE222h	2,089,472 + 34 = 2,089,506

Important

These modules are D16-only devices. That is, they may only be accessed via 16-bit words on even addresses. Attempts to access these modules via 8-bit bytes (D8) or 32-bit words (D32) will result in a bus error.

Register Definitions

All addresses are given in hexadecimal. Unless otherwise noted, register contents are unaffected by hard or soft resets. "X" or "x" denote bits which are "don't-care". All registers reside at even addresses and are WORD wide.

ID Register (Read)

Address = Base + 00H. This address returns the Hewlett-Packard VXI manufacturer ID of FFFFH

Device Type (Read)

Address = Base + 02H. This register defines the module's device class, addressing mode and manufacturer's ID according to the VXIbus specification. A read of this address returns 0151H (337₁₀) for an HP E1451 or a 0153H (339₁₀) for an HP E1452 (corresponding to a register-based device using the A16 address space only and manufactured by Hewlett-Packard)..

Status/Control Register (Read)

This register returns the I/O Module Status.

Address: B + 04 _H								
Bit #	15	14	13-9	8	7	6-4	3-0	
Value	A24	MODID*	1	TERM	INTEN*	ILS2-0	1	

Bit Definitions

- A24: Informs VXI controllers that the I/O module is not A24/A32 compatible. This bit is always clear.
- MODID*: A 1 in this field indicates the device is not selected via the P2 MODID line. A 0 indicates that the device is selected by a high state on the P2 MODID line. Reset value is 1.
- INTEN*: Interrupt Enabled. This field indicates the I/O Module may interrupt on the VXI backplane. Reset value is 0 (disabled), value of 1 enables.
- ILS2-0: The octal value read from this field indicates the interrupt level currently selected by the interrupt switch.
- TERM: Terminated. If this field is clear, the I/O module is an E1451 Unterminated Module. If set, the I/O module is an E1452 terminated module (50 ohm terminations on the local bus).

Status/Control Register (Write)

This register sets Control Bits.

Address: B + 04_H					
Bit #	15-8	7	6-4	3-1	0
Value	X	INTEN*	ILS2-0	X	SRESET

Bit Definitions

- **INTEN***: Interrupt Enabled. A write to this field enables the I/O Module to interrupt on the VXI backplane. Reset value is 1 (disabled), value of 0 enables.
- **ILS2-0**: The octal value written to this field sets the interrupt level which will be set when the I/O Module Interrupts the VXI backplane. Reset value is 0 (interrupts not enabled).
- **SRESET**: A write of 1 in this field Soft Resets the I/O Module. Bit 7 is set to 1 by Hard Reset (SYSRESET*) but not by SRESET.

Calibration ROM Register (Read/Write)

This address accesses the Calibration ROMs of the I/O Module.

CAUTION

DO NOT WRITE TO THIS REGISTER. DOING SO MAY ALTER THE CALIBRATION ROM'S CONTENTS, CAUSING THE MODULE TO FAIL AND REQUIRE FACTORY REPAIR.

Address: B + 06_H									
Bit #	15-8	7	6	5	4	3	2	1	0
Value	X	POD_1_OUT	POD_0_OUT	ROM_DATA_OUT	POD1_SEL	POD0_SEL	ROM_SEL	DATA_IN	CAL_ROM_CLK

I/O Port Registers

The following registers are common for each of the four I/O ports of the I/O Module (Port 0 through Port 3).

Sequence Memory (Read/Write)

This register contains the current address into sequence memory. It is used when reading or writing to that memory and it should be set to the first location of a sequence prior to starting that sequence. If bit 6 of the Configuration Register is set, the sequence memory address will increment by 1 whenever the Port Data Bus Register is accessed. Address: Port 0 = Base + 08H, Port 1 = Base + 16H, Port 2 = Base + 24H, Port 3 = Base + 32H

Bit #	15-0
Value	AC15-AC0

Branch Destination (Read/Write)

Address: Port 0 = Base + 0AH, Port 1 = Base + 18H, Port 2 = Base + 26H, Port 3 = Base + 34H

This register supplies the sequence memory address to which a jump is made when the sequencer encounters a set branch bit. All 16 bits are significant, and reading this location gives the last value written.

Bit #	15-0
Value	BA15-BA0

Port Data Bus (Read/Write)

Address: Port 0 = Base + 0CH, Port 1 = Base + 1AH, Port 2 = Base + 28H, Port 3 = Base + 36H

This register allows access to the internal pattern and control buses of the port.

Bit #	15-14	13	12	11	10	9-8	7-0
Value	X	COMP	TRIS	BRA	EOS	X	PD7-0

Bit Definitions

- Control Bus:
 - COMP: Enables (1) or disables (0) the compare test.
 - TRIS: Drives (0) or tri-states (1) the stimulus stage.
 - BRA: Branch. If set, causes jump to branch destination.
 - EOS: End of Sequence. If set, causes sequencer to stop.
- Pattern Bus PD7-0: Pattern Data.

Configuration Register (Read/Write)

Address: Port 0 = Base + 0EH, Port 1 = Base + 1CH, Port 2 = Base + 2AH, Port 3 = Base + 38H

This register controls what happens on the port's internal control and pattern buses. It also control the operation of the sequence memory. It can be read at any time and can be written when the port is stopped or paused (not receiving clocks).

Bit #	15-8	7	6	5	4-2	1-0
Value	X	COMEN	ENISC	ENIIOC*	PBRAM2-0	CBRAM1-0

Bit Definitions

- COMEN Compare Enable. When set (1), Compare is Enabled. When clear (0), compare function is disabled and any compare errors generated are cleared (see Status/Clock Source Register). Be sure that errors have been serviced before disabling compare mode.
- ENISC: Enable Injected Sequencer Clock. When set, the Address Counter will be incremented after each read or write to the Port Data Bus Register. This feature is used to load or dump sequence memory. Advancing the sequencer address in this way ignores the stop and branch bits.
- ENIIOC*: Enable Injected I/O Clock. When set (0, notice inverse logic sense), enables an I/O clock to be generated as part of a Read or Write to the Port Data Bus Register. This feature is used to directly control the input or output stages. The I/O clock will clock the input register, output register, tristate register (a group of tristate control flip flops), expected response register, compare flip flop, stop flip flop, and branch flip flop. If compare is enabled, an injected I/O clock operation could cause a compare error. If the branch or stop bits are true, an injected I/O operation could cause a stop or branch.
- PBRAM2-0: Pattern Bus/RAM. These bits control action on the pattern bus and operation of the pattern sequence memory.

Note

In end of record mode, the ram continues to write the contents of the input register into the last ram location even after the port has stopped. It is important to take the port out of record mode before the contents of the input register or the data on the port data bus is allowed to change.

PBRAM2-0	Function
000	Read (RAM drives bus)
001	Record Mode (see note above)
010	Safe (pattern bus tri-stated)
011	Access Input Stage
100	unused
101	Load RAM from VXI
110	Safe (pattern bus tri-stated)
111	Access Output Stage

Bit Definitions (continued)**● CBRAM2-0: Control Bus/RAM.**

CBRAM1-0	Function
00	Safe (Bus tri-stated)
01	Read (RAM drives bus)
10	Load RAM from VXI
11	Access control flip-flops

I/O Control (Read/Write)

Address: Port 0 = Base + 10H, Port 1 = Base + 1EH, Port 2 = Base + 2CH, Port 3 = Base + 3AH

This register controls the external, i.e., the user accessible, buses of the port. A hard or soft reset will set bits 0 - 7 to 0. The port should be stopped or paused (not receiving clocks) before writing to the output control register.

Bit #	15-8	7	6-4	3-2	1-0
Value	X	LIVE_I/O	unused	PDBUS1-0	CSTBUS1-0

Bit Definitions

- LIVE_I/O: When set, live I/O flip-flop will reflect live access.
- PDBUS1-0: Pod Bus Control. The Pod Bus connects the Module to the Pod. When the pod is not being used, this is the bus connected to the device under test. Reset causes the pod bus to go to the safe mode.

PDBUS1-0	Function
00	Safe (Pod Bus is Tristate)
01	Pod Input Buffer is Driver (used for all input modes)
10	Module Output Register can operate (used for output modes with pod absent)
11	Module Output Register Always Drives (used for output modes with pod present)

The following table shows the effects on the outputs by switching from one mode to another. This table is complete and does not assume that power is cycled between cases of pod being present and cases of pod being absent.

FROM	TO	OUTPUTS
reset, input, drive, operate, safe	safe	tristate
safe, drive, operate, input	input	tristate
safe, input, operate, drive	drive	drive
safe, input	operate	tristate
drive	operate	drive
operate	operate	unchanged

Bit Definitions

- **CSTBUS1-0: User Bus Control.** The user bus is what the user sees at the end of the pod. Reset causes the user bus to go to the input mode.

CSTBUS1-0	Function
00	User drives the Bus (used for all Pod input modes)
01	Pod Output Register can operate (used for Pod output modes using external clock)
10	Pod Output Buffer drives the Bus (not normally used but could be used for Live Output if you want to ignore the tristate control bit)
11	Pod Output Buffer can operate (used for Pod Output modes using internal clocks)

The following table shows the effects on the outputs by switching from one mode to another.

FROM	TO	OUTPUTS
reset, input, drive, register, buffer	input	tristate
input, drive, register, buffer	register	tristate
input, drive, register, buffer	drive	drive
input, register	buffer	tristate
drive	buffer	drive
buffer	buffer	unchanged

The drive mode may never be used. The following table assumes this case. It further ignores the input case.

FROM	TO	OUTPUTS
input, register, buffer	register	tristate
input, register	buffer	tristate
buffer	buffer	unchanged

Status/Clock Source Register (Write)

Address: Port 0 = Base + 12H, Port 1 = Base + 20H, Port 2 = Base + 2EH, Port 3 = Base + 3CH

This register performs two different control tasks. Bits 0-6 select the clock source for the sequencer. Bits 15, 14, and 9 control the starting and stopping of the sequencer. This is the Status/Clock Source Register for each I/O Port. If changing the internal clock source, the port should be stopped, not just paused. For other fields in the status/clock register, the port can be either stopped or paused (not receiving clocks) before writing.

Bit #	15	14	13-10	9	8	7	6-5	4	3-0
Value	RUN	CLSE*	X	STOP*	Unused	X	EXTCS1-0	PODECP	INTCS3-0

Bit Definitions

- Bits 15, 14, and 9: These three bits are ephemeral. Their states are not latched. It is the action of writing the specified value into them that produces their effect.

RUN: Setting this bit (1) causes the sequencer, if currently stopped, to enter its running state. If the sequencer is already running, setting this bit has no effect. Writing "0" into this bit has no effect.

CLSE*: Clear Stop Event. Setting this bit to "0" clears the event caused by a sequencer "RUN" to "STOP" transition. Setting this bit to "1" has no effect. The stop events of all four ports are OR'ed together to produce an interrupt request event for the module.

STOP*: If clear, stop. No action if set. Sending a stop command (write 0 to stop bit) to a running port will stop the port and cause a stop event interrupt. Sending a stop command to a stopped port does not cause a stop event interrupt. Sending a stop command to a port that is receiving clocks will cause it to stop. However, it may stop in an uncoordinated fashion. That is, the contents of the address counter may not match the behavior of the I/O stage. This warning should apply only to external clocks, since it is assumed that clocks from the Timing Module would be turned off before a stop command would be sent to a port.

- **PODECP:** Pod external Clock Polarity. If set, the pod's external clock is inverted (high-to-low edge clocks). If clear, the pod's external clock has normal polarity, i.e., the low-to-high clocks. This bit is used only if a pod is present. Toggling the pod external clock polarity bit will inject an external clock. This can be used to prime the pipe stage (pod output register) in the pod in the case of output - pod present - external clock. It can also be used to single step the port. In both of these cases, the external clock must be static.
- **EXTCS1-0:** External Clock Select. If external clock is selected, the internal clock select should be off. Inverted external clock select is normally used only when the pod is absent. If the pod is absent, the polarity of the external clock can be toggled to inject an external clock for the purposes of single step. The external clock must be static high or low in this instance.

EXTCS1-0	Function
00	External Clock Off
01	Non-inverted External Clock (used if Pod is present or not, internal clock select should be OFF)
10	Select Inverted External Clock (used if Pod is not present, internal clock select should be OFF)
11	unused

- **INTCS3-0: Internal Clock Select.** When using internal clocks, the external clock select is set OFF. Changing the clock source on a port that is running or PAUSED (not receiving clocks) may cause spurious clocks and uncoordinated operation. The port should be stopped before changing the clock source. Changing the internal clock source will require that a new calibration value be loaded into the mask/cal register.

INTCS3-0	Function
0000	Stimulus CLK 0
0001	Stimulus CLK 1
0010	Stimulus CLK 2
0011	Stimulus CLK 3
0100	Stimulus CLK 4
0101	Stimulus CLK 5
0110	OFF
0111	OFF
1000	Response CLK 0
1001	Response CLK 1
1010	Response CLK 2
1011	Response CLK 3
1100	Response CLK 4
1101	Response CLK 5
1110	OFF
1111	OFF

Status/Clock Source Register (Read)

Address: Port 0 = Base + 12H, Port 1 = Base + 20H, Port 2 = Base + 2EH, Port 3 = Base + 3CH

Bit #	15	14	13	12	11	10	9	8	7	6-5	4	3-0
Value	RUN	STOPEV	CMPSEI	DA_STATUS	X	CARD_OE*	QPIPE_OE*	QOBUF_OE*	X	EXTCS1-0	PODECP	INTCS3-0

Bit Definitions

- **RUN:** Run. If set, Port is presently Running, if clear the Port is presently stopped.
- **STOPEV:** Stop Event Interrupt. If set, the port had a RUN to STOP transition
- **CMPSEI:** Compare Error Interrupt. If set, a compare error occurred.
- **DA_STATUS:** Can be used to indicate whether the current output is due to direct access or due to sequencer.
- **CARD_OE*:** Card Output Enable. If set,
- **QPIPE_OE*:** Pipe Register Output Enable. If set.
- **QOBUF_OE*:** Output Register Output Enable. If set.
- **PODECP:** Pod external Clock Polarity. Readable status of this field.
- **EXTCS1-0:** External Clock Select. Readable status of this field.
- **INTCS1-0:** Internal Clock Select. Readable status of this field.

Mask/Calibration Value Register (Read/Write)

Address: Port 0 = Base + 14H, Port 1 = Base + 22H, Port 2 = Base + 30H, Port 3 = Base + 3EH

This is the Status/Clock Source Register for each I/O Port

Bit #	15-8	7-0
Value	CMPMK15-8	CALVAL 7-0

Bit Definitions

- **CMPMK15-8:** Compare Mask field. If a bit is set in this field, compare in this bit position, otherwise ignore.
- **CALVAL7-0:** Calibration Value field. Resolution is 100ps. There are minimum and maximum legal values.

Appendix Contents

Sequencer Specifications	A-1
Specifications For Ports Configured As Outputs	A-1
Specifications For Ports Configured As Inputs	A-2
External Clock Input Specifications (for HP E1451/E1452 And HP E1454): A-3	
Miscellaneous Specifications	A-3

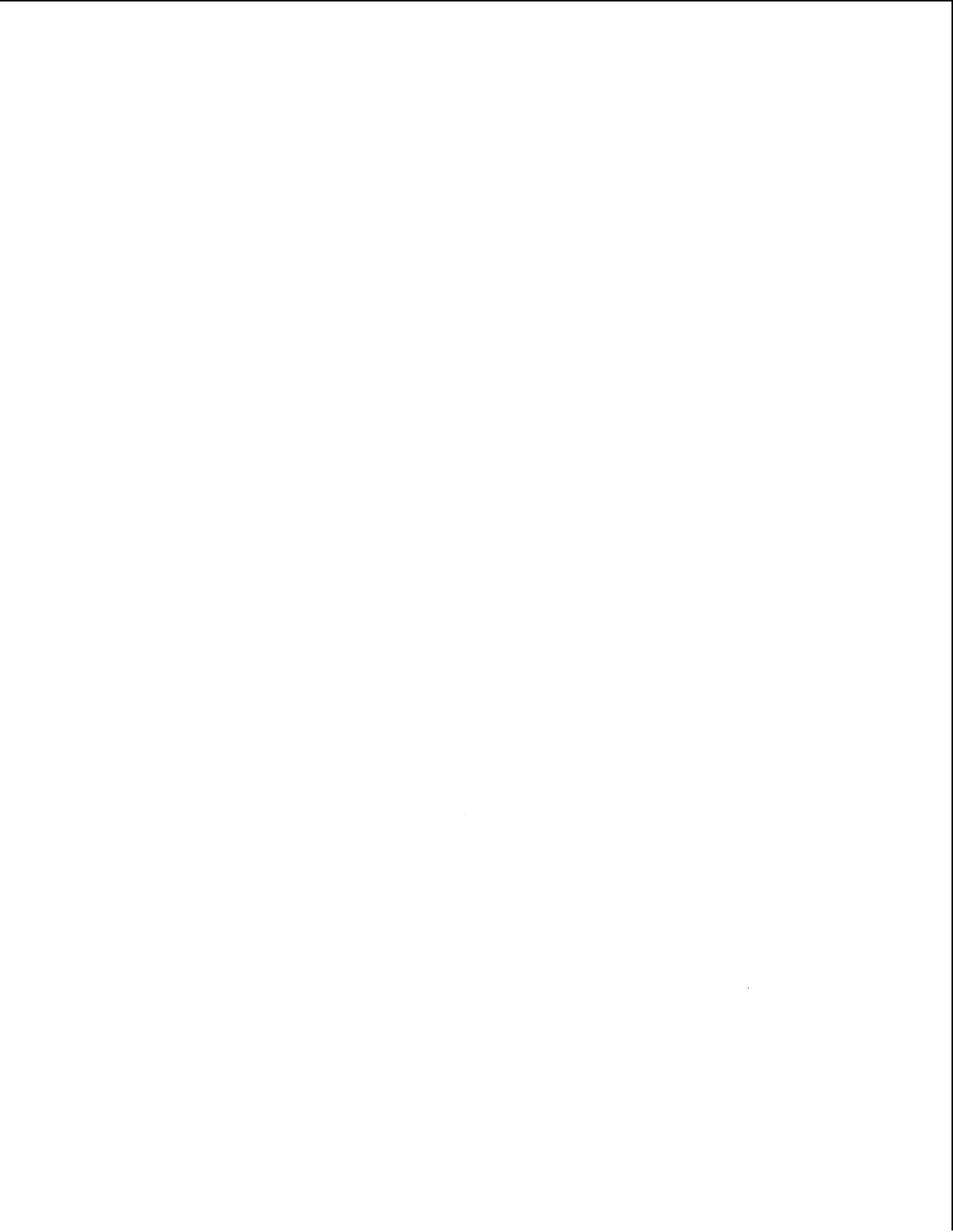

Appendix A

Specifications

Sequencer Specifications

Memory Depth: 65,536 (64k) vectors. Multiple test sequences may co-reside in memory.

Memory Functions: Stimulus Pattern or Response Pattern (expected or recorded) as well as control of Tri-state, Compare, and End-of-Sequence functions.

Specifications For Ports Configured As Outputs

Clock Source : External Clock, HP E1450 Timing Module (one of six Stimulus Pattern Clocks)

Output Levels:

HP E1451/E1452 Module Outputs

Maximum Continuous Output Current: $\pm 24\text{mA}$ per line

High, Open-Circuit: 4.4V, min.

Low, Open-Circuit: 0.1V, max.

Output Impedance: 50 Ω , typical

Capacitance (outputs disabled): 30pf, max.

Leakage Current (outputs disabled): 120 μA , max.

HP E1454 Pod Outputs

Maximum Continuous Output Current: $\pm 24\text{mA}$ per line

High, Open-Circuit: 4.3V, min.

High, Sourcing 24mA: 3.7V, min.

Low, Open-Circuit: 0.1V, max.

Low, Sinking 24mA: 0.44V, max

Capacitance (outputs disabled): 30pf, max.

Leakage Current (outputs disabled): 120 μA , max.

Tri-state:

Outputs can be disabled on a cycle-by-cycle basis by a control bit in the Sequencer memory, or by driving the Output Enable high. All eight pins of the port are controlled simultaneously.

Tri-State Control Input Levels and Loading (for HP E1451/E1452 and HP E1454):

High: >2.0V at <150 μ A

Low: <0.8V (internal pull-down)

Tri-state Control Input Delay:

HP E1451/E1452 without pod: 9ns typical, 14ns max

HP E1454 with pod: 8ns typical, 11ns max

Timing:

Pattern Rate: 0 to 20MHz

Skew:

Between output pins in the same port: 3ns, typical

Risetime: 6.5ns typical

Falltime: 7.0ns typical

Data Delay From External Clock:

HP E1451/E1452 without pod: 20ns typical, 27ns max

HP E1454 with pod: 14ns typical, 20ns max

Specifications For Ports Configured As Inputs

Clock Source: External Clock, HP E1450 Timing Module (1 of 6 Response Pattern Clocks)

Input Levels And Loading (for HP E1451/E1452 and HP E1454):

Low: <0.8V at <150 μ A

High: >2.0V (internal pull-up)

Capacitance: 30pf max.

Real-time Compare:

A programmable static mask can identify any pin of the port to be 'don't-care' for the duration of the test sequence. For those pins which are not masked, a Sequencer Control bit can enable the comparison of input patterns with expected response data on a cycle-by-cycle basis.

Input Timing:**Setup Time to External Clock**

HP E1451/E1452 without Pod: -1.6ns

HP E1454 with Pod: 5ns

Hold Time from External Clock

HP E1451/E1452 without Pod: 11.5ns

HP E1454 with Pod: 14ns

External Clock Input Specifications (for HP E1451/E1452 And HP E1454):

Minimum Period: 50ns

Minimum Pulse Width: 6ns

Polarity: Selectable

Input Levels (for HP E1451/E1452 or HP E1454):

Low: <0.8V at <150 μ A

High: >2.0V (internal pull-up)

Capacitance: 30pf max.

Miscellaneous Specifications

Power Requirements:

+5.0V (excluding load currents): 1.5A peak, 40ma dynamic

-5.2V: 2.2A peak, 200mA dynamic

-2.0V: 0.6A peak, 80mA dynamic

+12.0V: 0.1A peak, 10mA dynamic

Cooling Requirements:

Average Power/slot: 22w

Ambient Temperature:

Operating: 0 to 55°C

Storage: -40 to 75°C

Humidity: 65 % relative from 0 to 40°C

Operating temp: 0 to 55°C

Storage temp: -40 to 75°C

Airflow Requirements (for 10°C rise): 2.0 liter/sec at 1.2 mm water

Weight: 1.1kg

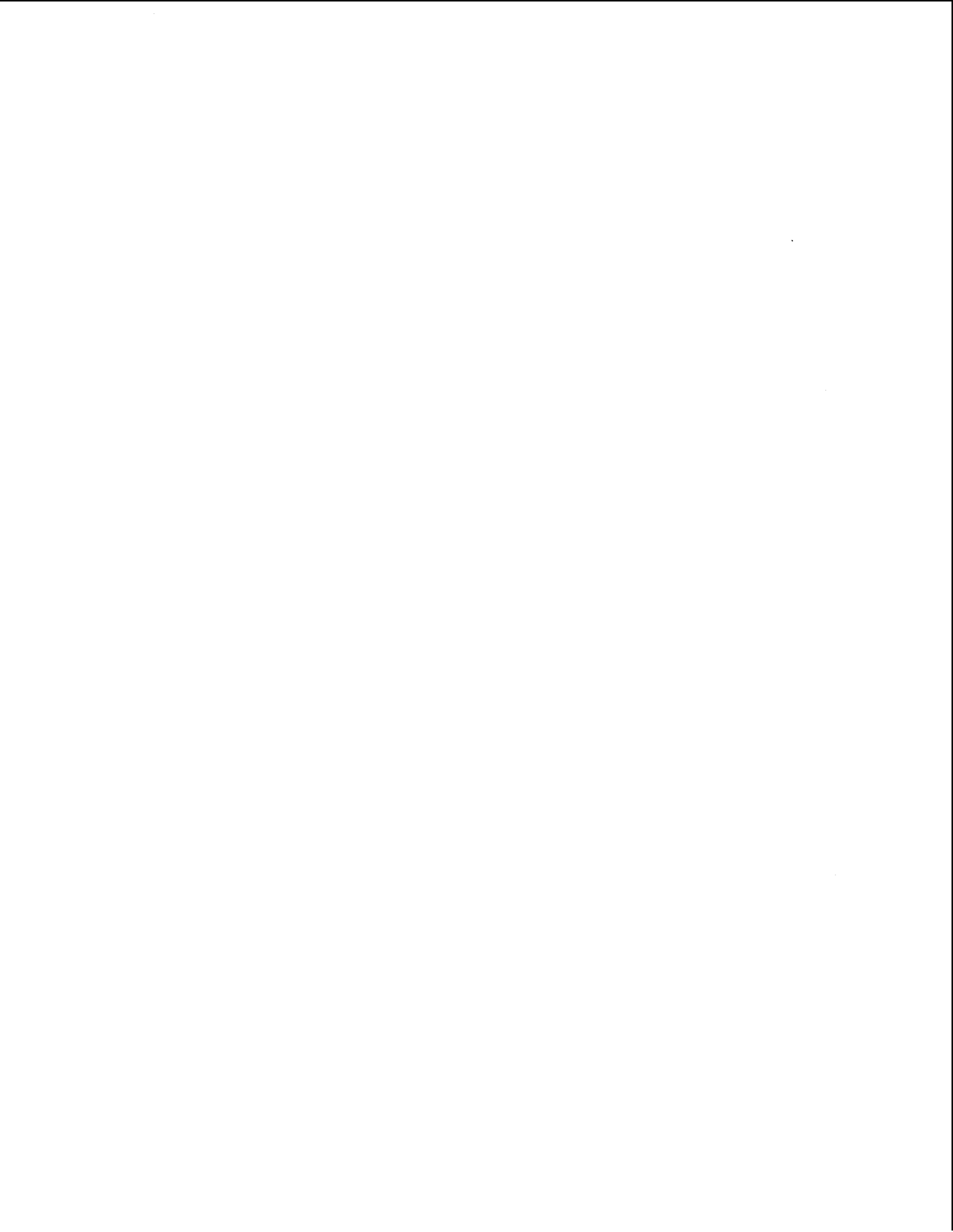

Index

A

A16 address space using the command module, 3-3
A16 address space when not using the HP E1405 command module, 3-3
Address guidelines, logical, 2-2
Address space using the command module, A16, 3-3
Address space when not using the HP E1405 command module, A16, 3-3
Address switch, logical, 2-2
Address, base, 3-3
Addresses, register, 3-1

B

Base address, 3-3
Branch destination, 3-7

C

Calibration ROM register (write), 3-6
Configuration information, 2-2
Configuration register, 3-8
Control, I/O, 3-10

D

Data bus, port, 3-8
Definitions, register, 3-5
Destination, branch, 3-7
Device type (read), 3-5

E

E1451/E1452 pattern I/O hardware description, HP, 1-1
E1454 pattern I/O pod description, HP, 1-3
External clock input specifications, A-3

F

Fixturing techniques, recommended, 2-7

H

HP E1451/E1452 pattern I/O hardware description, 1-1
HP E1454 pattern I/O pod description, 1-3

I

I/O control, 3-10
I/O port registers, 3-6
ID register, 3-5
Information, configuration, 2-2
Information, wiring, 2-4

L

Logical address guidelines, 2-2
Logical address switch, 2-2

M

Mask/Calibration value register, 3-14
Memory, sequence, 3-6
Miscellaneous specifications, A-3

O

Offset, register, 3-3

P

Port data bus, 3-8
Port registers, I/O, 3-6
Ports configured as inputs, specifications, A-2
Ports configured as outputs, specifications, A-1

R

Recommended fixturing techniques, 2-7
Register addresses, 3-1
Register definitions, 3-5
Register offset, 3-3
Register, configuration, 3-8
Register, ID, 3-5
Register, status/control, 3-5 - 3-6
ROM register, calibration, 3-6

S

Sequence memory, 3-6
Sequencer specifications, A-1
Source register, status/clock, 3-12, 3-14
Specifications for ports configured as inputs, A-2

Specifications for ports configured as outputs, A-1
Specifications, miscellaneous, A-3
Specifications, sequencer, A-1
Stand-alone instrument, 1-4
Status/Clock source register, 3-12, 3-14
Status/Control register (read), 3-5
Status/Control register (write), 3-6

T

Type, device, 3-5

U

Using the HP E1451/E1452 as a stand-alone instrument,
1-4

V

Value register, mask/calibration, 3-14

W

Wiring information, 2-4



HEADQUARTERS OFFICES

If there is no sales office listed for your area, contact one of these headquarters offices

NORTH/CENTRAL AFRICA

Hewlett-Packard S.A.
7, rue du Bois-du-Lan
CH-1217 MEYRIN 1, Switzerland
Tel: (022) 83 12 12
Telex: 27835 hmea
Cable: HEWPACKSA Geneva

ASIA

Hewlett-Packard Asia Ltd.
47/F, 26 Harbour Rd.,
Wanchai, HONG KONG
G.P.O. Box 863, Hong Kong
Tel: 5-8330833
Telex: 76793 HPA HX
Cable: HPASIAL TD

EASTERN EUROPE

Hewlett-Packard Ges.m.b.H.
Liebigasse 1
P.O. Box 72
A-1222 VIENNA, Austria
Tel: (222) 2500-0
Telex: 13 4425 HEPA A

NORTHERN EUROPE

Hewlett-Packard S.A.
V. D. Hooplaan 241
P.O. Box 999
NL-1183 AG AMSTELVEEN
The Netherlands
Tel: 20 547999
Telex: 18 919 hpner

SOUTH EAST EUROPE

Hewlett-Packard S.A.
World Trade Center
110 Avenue Louis Casai
1215 Corntrin, GENEVA, Switzerland
Tel: (022) 98 96 51
Telex: 27225 hpeer

EASTERN USA

Hewlett-Packard Co.
4 Choke Cherry Road
ROCKVILLE, MD 20850
Tel: (301) 948-6370

MIDWESTERN USA

Hewlett-Packard Co.
5201 Tollview Drive
ROLLING MEADOWS, IL 60008
Tel: (312) 255-9800

SOUTHERN USA

Hewlett-Packard Co.
2000 South Park Place
ATLANTA, GA 30339
Tel: (404) 955-1500

WESTERN USA

Hewlett-Packard Co.
5161 Lankershim Blvd.
NORTH HOLLYWOOD, CA 91801
Tel: (818) 505-5600

MEDITERRANEAN AND MIDDLE EAST

Hewlett-Packard S.A.
Mediterranean and Middle East
Operations
Atrna Centre
32 Kifissias Ave.
Paradissos-Amarousion, ATHENS
Greece
Tel: 682 88 11
Telex: 21-6588 HPAT GR
Cable: HEWPACKSA Athens

OTHER INTERNATIONAL AREAS

Hewlett-Packard Co.
Intercontinental Headquarters
3495 Deer Creek Road
PALO ALTO, CA 94304
Tel: (415) 857-1501
Telex: 034-8300
Cable: HEWPACK

ARGENTINA

Hewlett-Packard Argentina S.A.
Montaneses 2140/50
1428 BUENOS AIRES
Tel: 781-4059/69
Cable: HEWPACKARG

AUSTRALIA

Hewlett-Packard Australia Ltd.
31-41 Joseph Street
P.O. Box 221
BLACKBURN, Victoria 3130
Tel: 895-2895
Telex: 31-024
Cable: HEWPAARD Melbourne

Hewlett-Packard Australia Ltd.
17-23 Talavera Road
P.O. Box 308
NORTH RYDE, N.S.W. 2113
Tel: 888-4444
Telex: 21561
Cable: HEWPAARD Sydney

AUSTRIA

Hewlett-Packard Ges.m.b.H.
Liebigasse 1
P.O. Box 72
A-1222 VIENNA
Tel: (0222) 2500-0
Telex: 134425 HEPA A

BELGIUM

Hewlett-Packard Belgium S.A./N.V.
Bvd de la Woluwe, 100
Woluwe-la

B-1200 BRUSSELS
Tel: (02) 762-32-00
Telex: 23-494 paloben bru

BRAZIL

Hewlett-Packard do Brasil
l.e.C. Ltda.
Alameda Rio Negro, 750
ALPHAVILLE
06400 Barueri SP
Tel: (011) 421.1311
Telex: (011) 33872 HPBR-BR
Cable: HEWPACK Sao Paulo

Hewlett-Packard do Brasil
l.e.C. Ltda.
Praça de Botafogo 228
8° Andar-conj 814
Edifício Argentina - Ala A
22250 RIO DE JANEIRO, RJ
Tel: (021) 552-6422
Telex: 21905 HPBR-BR
Cable: HEWPACK Rio de Janeiro

CANADA

Hewlett-Packard (Canada) Ltd.
11120-178th Street
EDMONTON, Alberta T5S 1P2
Tel: (403) 486-6666

Hewlett-Packard (Canada) Ltd.
17500 Trans Canada Highway
South Service Road
KIRKLAND, Quebec H9J 2X8
Tel: (514) 897-4232
Telex: 058-21521

Hewlett-Packard (Canada) Ltd.
6877 Goreway Drive
MISSISSAUGA, Ontario L4V 1M8
Tel: (416) 678-9430
Telex: 069-8644

Hewlett-Packard (Canada) Ltd.
2670 Queensview Dr.
OTTAWA, Ontario K2B 8K1
Tel: (613) 820-6483

CHINA, People's Republic of

China Hewlett-Packard Co., Ltd.
P.O. Box 9610, Beijing
4th Floor, 2nd Watch Factory Main
Bldg.
Shuang Yu Shou, Bei San Huan Road
Hai Dian District
BEIJING
Tel: 28-0567
Telex: 22601 CTSHP CN
Cable: 1920 Beijing

DENMARK

Hewlett-Packard A/S
Kongevejen 25
DK-3460 BIRKERØD
Tel: (02) 81-66-40
Telex: 37409 hpas dk

FINLAND

Hewlett-Packard Oy
Pitkänkatu 17
02200 ESPOO
Tel: 00358-0-88721
Telex: 121563 HEWPA SF

FRANCE

Hewlett-Packard France
Chemin des Mouilles
Boite Postale 162
69131 ECULLY Cedex (Lyon)
Tel: (78) 133-81-25
Telex: 310617F

Hewlett-Packard France
Parc d'activités du Bois Briard
Avenue du Lac
91040 EVRY Cedex
Tel: (80) 77-83-83
Telex: 682315F

Hewlett-Packard France
Zone Industrielle de Courtabouff
Avenue des Tropiques
91947 LES ULIS Cedex (Orsay)
Tel: (89) 07-78-25
Telex: 800048F

GERMAN FEDERAL REPUBLIC

Hewlett-Packard GmbH
Vertreibszentrum Mitte
Hewlett-Packard-Strasse
D-6380 BAD HOMBURG
Tel: (06172) 16-0
Fax: (06172) 16-1309

Hewlett-Packard GmbH
Vertreibszentrum Südwest
Schickardstrasse 2
D-7030 BOBLINGEN
Tel: (07031) 14-0
Fax: (07031) 14-6429

Hewlett-Packard GmbH
Vertreibszentrum Süd
Eschenstrasse 5
D-8028 TAUFKIRCHEN
Tel: (089) 81207-0
Fax: (089) 81207-300

GREECE

Hewlett-Packard A.E.
178, Kifissias Avenue
8th Floor
Halandri-ATHENS
Greece
Tel: 6471543, 6471673, 6472971
Telex: 221 286 HPHLGR

HONG KONG

Hewlett-Packard Hong Kong, Ltd.
G.P.O. Box 795
5th Floor, Sun Hung Kai Centre
30 Harbour Road
HONG KONG
Tel: 5-8323211
Telex: 66678 HEWPA HX
Cable: HEWPACK HONG KONG

ICELAND

Hewlett-Packard Iceland
Hoeldabakka 9
110 REYKJAVIK
Tel: (1) 67 1000

INDIA

Blue Star Ltd.
13 Community Center
New Friends Colony
NEW DELHI 110 065
Tel: 633182, 636674
Telex: 031-61120
Cable: BLUEFROST

INDONESIA

BERCA Indonesia P.T.
P.O. Box 2497/Jkt
Antara Bldg., 11th Floor
Jl. Medan Merdeka Selatan 17
JAKARTA-PUSAT
Tel: 343989
Telex: 46748 BERSAL IA

IRELAND

Hewlett-Packard Ireland Ltd.
82/83 Lower Leeson Street
DUBLIN 2
Tel: 0001 608800
Telex: 30439

ISRAEL

Computation and Measurement
Systems (CMS) Ltd.
11 Masad Street
67060
TEL-AVIV
Tel: 388 388
Telex: 33569 Motil IL

ITALY

Hewlett-Packard Italiana S.p.A.
Via G. di Vittorio 9
I-20063 CERNUSCO SUL
NAVIGLIO
(Milano)
Tel: (02) 923691
Telex: 334632

Hewlett-Packard Italiana S.p.A.
Viale C. Pavese 340
I-00144 ROMA EUR
Tel: (06) 54831
Telex: 610514

JAPAN

Yokogawa-Hewlett-Packard Ltd.
Chuo Bldg.,
4-20 Nishinakajima, 5 Chome
Yodogawa-ku
OSAKA, 532
Tel: (06) 304-6021
Telex: YHPOSA 523-3624
Yokogawa-Hewlett-Packard Ltd.
29-21 Takaido-Higashi, 3 Chome
Suginami-ku TOKYO 168
Tel: (03) 331-6111
Telex: 232-2024 YHPTOK

Yokogawa-Hewlett-Packard Ltd.
Yasuda Seimei Nishiguchi Bldg.
30-4 Tsuruya-cho, 3 Chome
Kanagawa-ku, YOKOHAMA 221
Tel: (045) 312-1252



SALES & SUPPORT OFFICES

Arranged alphabetically by country

KOREA

Samsung Hewlett-Packard Co. Ltd.
Dongbang Yeouido Building
12-16th Floors
36-1 Yeouido-Dong
Youngdeungpo-Ku
SEOUL
Tel: 784-4666, 784-2666
Telex: 25166 SAMSAN K

MALAYSIA

Hewlett-Packard Sales (Malaysia)
Sdn. Bhd.
9th Floor
Chung Khaiw Bank Building
46, Jalan Raja Laut
50350 KUALA LUMPUR
Tel: 2986555
Telex: 31011 HPSM MA

MEXICO

Hewlett-Packard de Mexico,
S.A. de C.V.
Monte Pavoux No. 111
Lomas de Chapultepec
11000 MEXICO, D.F.
Tel: 5-40-62-28, 72-86, 50-25
Telex: 17-74-507 HEWPAK MEX

NETHERLANDS

Hewlett-Packard Nederland B.V.
Startbaan 16
NL-1187 XR AMSTELVEEN
P.O. Box 667
NL-1180 AR AMSTELVEEN
Tel: (020) 547-8911
Telex: 13 216 HEPA NL

NORWAY

Hewlett-Packard Norge A/S
Osterdalen 16-18
P.O. Box 34
N-1345 OESTERAAS
Tel: 0047/2/24 60 90
Telex: 76621 hpnas n

PUERTO RICO

Hewlett-Packard Puerto Rico
101 Munoz Rivera Av
Esq. Calle Ochoa
HATO REY, Puerto Rico 00918
Tel: (809) 754-7800

SAUDI ARABIA

Modern Electronics Establishment
Hewlett-Packard Division
P.O. Box 1228
Redec Plaza, 6th Floor
JEDDAH
Tel: 644 96 28
Telex: 4027 12 FARNAS SJ
Cable: ELECTA JEDDAH

SINGAPORE

Hewlett-Packard Singapore (Sales)
Pte. Ltd.
808-00 Incense House
450-2 Alexandra Road
Alexandra P.O. Box 58
SINGAPORE, 9115
Tel: 4731788
Telex: 34209 HPSGSO RS
Cable: HEWPAK, Singapore

SOUTH AFRICA

Hewlett-Packard So Africa (Pty.) Ltd.
9 Eastern Service Road
Eastgate Ext. 3
SANDTON 2144
Tel: 802-5111, 802-5125
Telex: 4-20877 SA
Cable: HEWPAK Johannesburg

SPAIN

Hewlett-Packard Española, S.A.
Ctra. de la Coruña, Km. 16, 400
Las Rozas
E-MADRID
Tel: (1) 637.00.11
Telex: 23515 HPE

SWEDEN

Hewlett-Packard Sverige AB
Skaiholmsgatan 9, Kista
Box 19
S-16393 SPÅNGA
Tel: (08) 750-2000
Telex: (854) 17886
Telefax: (08) 7527781

SWITZERLAND

Hewlett-Packard (Schweiz) AG
7, rue du Bois-du-Lan
Case postale 365
CH-1217 MEYRN 1
Tel: (0041) 22-83-11-11
Telex: 27333 HPAG CH

TAIWAN

Hewlett-Packard Taiwan Ltd.
8th Floor, Hewlett-Packard Building
337 Fu Hang North Road
TAIPEI
Tel: (02) 712-0404
Telex: 24439 HEWPAK
Cable: HEWPAK Taipei

TURKEY

Teknim Company Ltd.
Iran Caddesi No. 7
Karaklidere
ANKARA
Tel: 275800
Telex: 42155 TKNM TR

UNITED KINGDOM

ENGLAND

Hewlett-Packard Ltd.
Heathside Park Road
Chaddle Heath
STOCKPORT
Cheshire
SK3 0RB
Tel: 061-428-0828
Telex: 668068

Hewlett-Packard Ltd.
King Street Lane
Winninsh, WOKINGHAM
Berkshire RG11 5AR
Tel: 0734 784774
Telex: 847178

SCOTLAND

Hewlett-Packard Ltd.
SOUTH QUEENSFERRY
West Lothian, EH30 9TG
Tel: 031 331 1188
Telex: 72682

UNITED STATES

Alabama

Hewlett-Packard Co.
420 Wynn Drive
HUNTSVILLE, AL 35805
Tel: (205) 830-2000

Arizona

Hewlett-Packard Co.
8080 Pointe Parkway West
PHOENIX, AZ 85044
Tel: (602) 273-8000

California

Hewlett-Packard Co.
1421 S. Manhattan Av.
FULLERTON, CA 92831
Tel: (714) 999-6700

Hewlett-Packard Co.
5651 West Manchester Ave.
LOS ANGELES, CA 90045
Tel: (213) 337-8000
Telex: 910-325-6608

Hewlett-Packard Co.
9606 Aero Drive
SAN DIEGO, CA 92123
Tel: (619) 279-3200

Hewlett-Packard Co.
3003 Scott Boulevard
SANTA CLARA, CA 95054
Tel: (408) 988-7000
Telex: 910-338-0586

Colorado

Hewlett-Packard Co.
24 Inverness Place, East
ENGLEWOOD, CO 80112
Tel: (303) 649-5000

Connecticut

Hewlett-Packard Co.
47 Barnes Industrial Road South
WALLINGFORD, CT 06492
Tel: (203) 265-7801

Florida

Hewlett-Packard Co.
2901 N.W. 82nd Street
FORT LAUDERDALE, FL 33309
Tel: (305) 973-2800

Hewlett-Packard Co.
6177 Lake Eleanor Drive
ORLANDO, FL 32809
Tel: (305) 859-2900

Georgia

Hewlett-Packard Co.
2000 South Park Place
ATLANTA, GA 30339
Tel: (404) 955-1500
Telex: 810-766-4890

Illinois

Hewlett-Packard Co.
5201 Tollview Drive
ROLLING MEADOWS, IL 60008
Tel: (312) 255-9800
Telex: 910-687-1066

Indiana

Hewlett-Packard Co.
11911 N. Meridian St.
CARMEL, IN 46032
Tel: (317) 844-4100

Louisiana

Hewlett-Packard Co.
160 James Drive East
ST. ROSE, LA 70087
P.O. Box 1449
KENNER, LA 70063
Tel: (504) 467-4100

Maryland

Hewlett-Packard Co.
3701 Koppers Street
BALTIMORE, MD 21227
Tel: (301) 644-5800
Telex: 710-862-1943

Hewlett-Packard Co.
2 Choke Cherry Road
ROCKVILLE, MD 20850
Tel: (301) 948-6370

Massachusetts

Hewlett-Packard Co.
1775 Minuteman Road
ANDOVER, MA 01810
Tel: (617) 682-1500

Michigan

Hewlett-Packard Co.
39550 Orchard Hill Place Drive
NOVI, MI 48050
Tel: (313) 349-9200

Minnesota

Hewlett-Packard Co.
2025 W. Larpentour Ave.
ST. PAUL, MN 55113
Tel: (612) 644-1100

Missouri

Hewlett-Packard Co.
1001 E. 101st Terrace Suite 120
KANSAS CITY, MO 64131-3368
Tel: (816) 941-0411

Hewlett-Packard Co.
13001 Hollenberg Drive
BRIDGETON, MO 63044
Tel: (314) 344-5100

New Jersey

Hewlett-Packard Co.
120 W. Century Road
PARAMUS, NJ 07653
Tel: (201) 265-5000

New Mexico

Hewlett-Packard Co.
7801 Jefferson N.E.
ALBUQUERQUE, NM 87109
Tel: (505) 823-6100

New York

Hewlett-Packard Co.
9600 Main Street
CLARENCE, NY 14031
Tel: (716) 759-8621

Hewlett-Packard Co.
7641 Henry Clay Blvd.
LIVERPOOL, NY 13088
Tel: (315) 451-1820

Hewlett-Packard Co.
3 Crossways Park West
WOODBURY, NY 11797
Tel: (516) 882-7800

North Carolina

Hewlett-Packard Co.
5805 Roanne Way
GREENSBORO, NC 27420
Tel: (919) 852-1800

Ohio

Hewlett-Packard Co.
15885 Sprague Road
CLEVELAND, OH 44136
Tel: (216) 243-7300

Hewlett-Packard Co.
9080 Springboro Pike
MANSBURG, OH 45342
Tel: (513) 433-2223

Hewlett-Packard Co.
675 Brooksedge Blvd.
WESTERVILLE, OH 43081
Tel: (614) 891-3344

Oklahoma

Hewlett-Packard Co.
3525 N.W. 58th St.
Suite C-100
OKLAHOMA CITY, OK 73112
Tel: (405) 946-9499

Oregon

Hewlett-Packard Co.
9255 S. W. Pioneer Court
WILSONVILLE, OR 97070
Tel: (503) 682-8000

Pennsylvania

Hewlett-Packard Co.
111 Zeta Drive
PITTSBURGH, PA 15238
Tel: (412) 782-0400

Hewlett-Packard Co.
2750 Monroe Boulevard
VALLEY FORGE, PA 19482
Tel: (215) 666-9000

Texas

Hewlett-Packard Co.
1826-P Kramer Lane
AUSTIN, TX 78758
Tel: (512) 835-6771

Hewlett-Packard Co.
10535 Harwin Drive
HOUSTON, TX 77036
Tel: (713) 776-8400

Hewlett-Packard Co.
930 E. Campbell Rd.
RICHARDSON, TX 75081
Tel: (214) 231-6101

Hewlett-Packard Co.
1020 Central Parkway South
SAN ANTONIO, TX 78232
Tel: (512) 494-8336

Utah

Hewlett-Packard Co.
3530 W. 2100 South St.
SALT LAKE CITY, UT 84119
Tel: (801) 974-1700

Virginia

Hewlett-Packard Co.
4305 Cox Road
GLEN ALLEN, VA 23060
Tel: (804) 747-7750

Washington

Hewlett-Packard Co.
15815 S.E. 37th Street
BELLEVUE, WA 98006
Tel: (206) 643-4000

Wisconsin

Hewlett-Packard Co.
275 N. Corporate Dr.
BROOKFIELD, WI 53005
Tel: (414) 794-8800

VENEZUELA

Hewlett-Packard de Venezuela C.A.
3A Transversal Los Ruces Norte
Edificio Segre 2 & 3
Apartado 50933
CARACAS 1050
Tel: (582) 239-4133
Telex: 251046 HEWPAK

YUGOSLAVIA

Do Hermes
General Zdanova 4
YU-11000 BEOGRAD
Tel: (011) 342 641
Telex: 11433